



## 温馨提示!

因印刷关系, 产品颜色可能与实物略有偏差, 请以实物为准, 图片仅供参考;  
本公司对本图册资料保留最终解释权。



铝合金型材  
建材·装饰材料

ALUMINUM ALLOY  
PROFILE BUILDING MATERIALS  
AND DECORATIVE MATERIALS

2023 款·宝典

广东铝多多铝业有限公司

# 企业介绍

## ENTERPRISE INTRODUCTION

广东铝多多铝业有限公司前身系佛山市南海广南铝业有限公司，成立于 2010 年，铝多多经历几年的艰辛探索，不断发展壮大。为给更好地迎合市场，满足广大的客户需求，广东铝多多创始人带领原班精英人士，在素有“中国铝材第一镇”之称的广东省佛山市南海区大沥镇这块风水宝地，斥巨资百万元于 2014 年 9 月 19 日成立了佛山市南海广贝铝业有限公司、于 2018 年 1 月 12 日在斥巨资千万元成立了佛山市进基金属制品有限公司——铝多多铝材厂

广东铝多多铝业有限公司是集铝合金型材产品研发、生产与销售为一体十五综合型大型铝业，公司拥有小洞工业区和长红科技园两大基地，占地总面积 50000 多平方米，主要研发与生产建筑铝型材、工业型材、波浪板、长城板、幕墙系列、天花吊管、扁管、圆管、加强筋、智能百叶窗等各种工业用料；同时也是胚料、现货生产厂家。

铝多多铝业年生产力 3 万吨，公司建立健全了从模具设计与制造、铝合金研发与加工、铝型材表面处理、“高、精、尖”深加工等完整的铝加工产业链及完善的生产运作管理系统，势必打造行业领先品牌。

“铝多多”始终奉行“以质量求生存，以科技求创新，以规模求效益、以品牌求发展”的经营之道，重诚信、守信誉，持续改进，时刻把握市场的先机，实现产品的空间合理化、自然化、个性化。使产品创造出一个“时代化”的概念。多元化的品种、斑斓的色彩、通透的光泽及超强的耐腐蚀度，为广大客户创造出一个全新的生活空间。

Guangdong Aluminum Duoduo Aluminum Co., Ltd., formerly known as Foshan Nanhai Guangnan Aluminum Co., Ltd., was founded in 2010. After several years of hard exploration, Aluminum Duoduo has continued to grow. In order to better cater to the market and meet the needs of the vast number of customers, the founder of Guangdong Aluminum Duoduo led the elite of the original class to establish Foshan Nanhai Guangbei Aluminum Co., Ltd. on September 19, 2014, at Dali Town, Nanhai District, Foshan City, Guangdong Province, which is known as "the first town of aluminum materials in China" On January 12, 2018, Foshan Jinji Metal Products Co., Ltd. - Luduoduo Aluminum Factory was established with a huge investment of ten million yuan

Guangdong Aluminum Duoduo Aluminum Industry Co., Ltd. is a comprehensive large-scale aluminum industry integrating the research and development, production and sales of aluminum alloy profile products. The company has two bases, Xiaodong Industrial Zone and Changhong Science and Technology Park, covering a total area of more than 50000 square meters. It mainly develops and produces various industrial materials such as architectural aluminum profiles, industrial profiles, corrugated plates, Great Wall panels, curtain wall series, ceiling hanging tubes, flat tubes, round tubes, stiffeners, intelligent shutters, etc; It is also a manufacturer of raw materials and spot goods.

With an annual production capacity of 30000 tons, the company has established and improved a complete aluminum processing industry chain and a complete production operation management system from mold design and manufacturing, aluminum alloy research and development and processing, aluminum profile surface treatment, "high, precision, and sharp" deep processing, which is bound to create an industry-leading brand.

"Luduoduo" always adheres to the business principle of "survival by quality, innovation by science and technology, efficiency by scale, and development by brand". It is committed to honesty, credibility, continuous improvement, and always grasp the market opportunity to realize the rationalization, naturalization and personalization of product space. Make the product create a "modern" concept. The diversified varieties, colorful colors, transparent luster and strong corrosion resistance create a new living space for customers.



# PRODUCTION SPOT BASE

## 现货基地



铝型材现货仓储基地，4000 多吨现货铝材，  
为铝建筑行业合作伙伴的发展保驾护航。

The spot storage base of aluminum profiles, with more than 4000 tons of spot aluminum products, will escort the development of partners in the aluminum construction industry.



# COMPANY SIZE

## 公司规模





## PRODUCTION WORKSHOP 生产车间



广东铝多多铝业有限公司一条龙生产挤压、喷涂、加工等  
建筑门窗铝型材行业领先品牌



厂家直营铝材行业真正的一条龙  
品牌保护经营 技术领先



始于诚信，成于专注，创新为限，共赢为魂  
企业愿景：致力于打造高端门窗型材领军品牌  
企业使命：推进行业技术革新，打造一流产品  
企业精神：自主创新、不断突破、精益求精  
企业荣誉：专注、创新、诚信、共赢



## METICULOUS SERVICE

### 细致服务

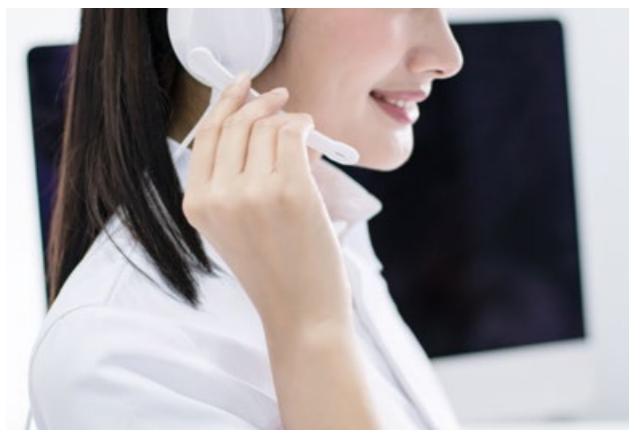

## CUSTOMER FIRST AND WIN-WIN!

### 客户至上 携手共赢！

我们在营销过程中，以客户的利益高于一切为宗旨！力求做好每一个环节、全面落实市场调研拓展市场，综合市场反馈信息，作出科学决策。建立和推广的优质品牌，为客户提供一个完善、健康、稳定的营销服务网络。

在销售服务中，我们时刻用心聆听、了解客户需求，如有异常客诉，立即改善解决，为客户提供更专业的全方位服务项目。

## PROJECT EXAMPLE DISPLAY

### 工程实例展示



## PROJECT EXAMPLE DISPLAY

### 工程实例展示



建筑的线条具有特殊的表现力和多种造型的功能，曲直线成一层层水波般而上，且线条粗细、曲折富有变化，给人以优雅、柔和流程、轻快活跃的感觉

The lines of the building have special expressive force and various modeling functions. The curves and straight lines form layers of water, and the lines are thick, thin and tortuous, giving people a feeling of elegance, soft process, lightness and activity



APPLICABLE  
PLACE

## 适用场所



工程建筑



车站

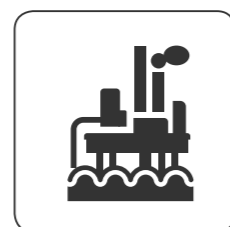

工厂

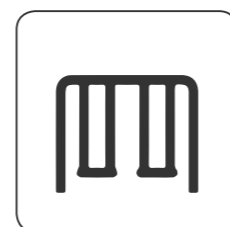

公共设施



住宅



机场

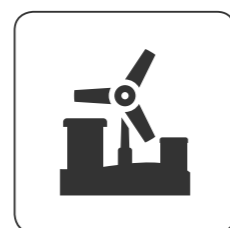

公共场所



超市



舞厅



宾馆



餐厅

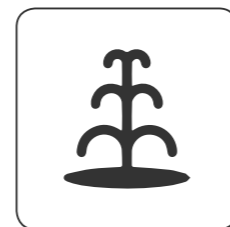

公园



学校



购物中心



运动场

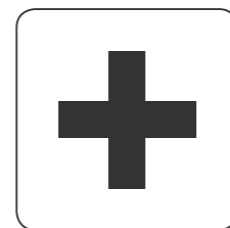

医院

## PRODUCT CATALOG

# 产品目录

波浪板 - 长城系列	01-29
天花板系列	30-38
圆管系列	39-41
子弹头系列	42-43
滴水挂片系列	44-44
百叶系列	45-48
铝艺系列	49-58
组合管系列	59-66
槽管系列	67-75
经典系列	76-76
加强筋系列	77-82
地脚线系列	82-83
龙骨系列	84-87
盖板系列	88-89
幕墙系列	89-94
方管规格系列	95-102
圆管规格系列	103-104
角铝规格系列	105-106

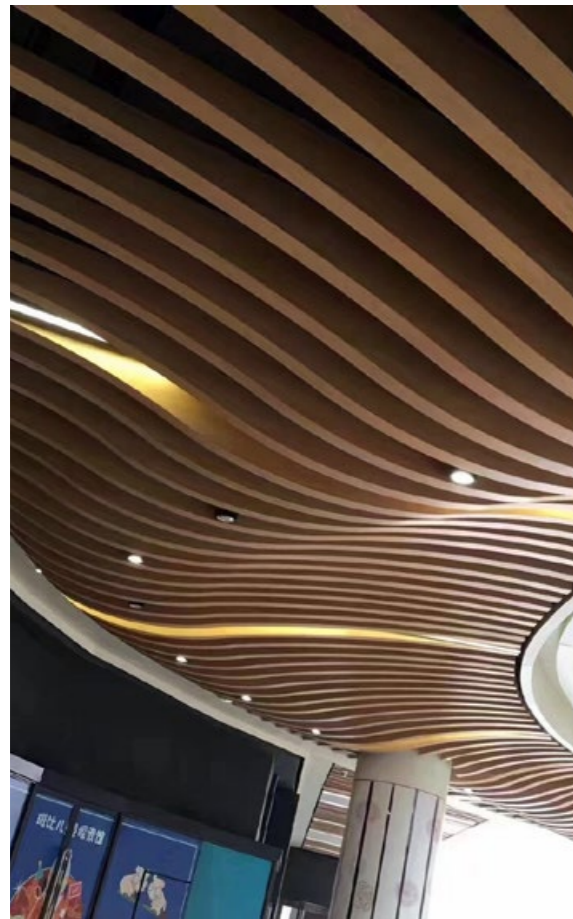

WAVE PLATE - GREAT WALL SERIES  
波浪板 - 长城系列

铝型材表面经过喷涂后，外观非常漂亮，且耐脏，一旦涂上油污非常易清洁，组装成品时，根据不同的承重采用不同规格的型材，并采用配图铝型材配件，不需要焊接，较环保，而且安装、拆卸，轻巧便于携带、搬移极为方便。



彩涂铝卷  
Painted aluminum coil



耐候、防潮  
Weather and moisture resistance



装饰性强  
Decorative nature



易安装  
Easy to install



深加工  
Deep processing



自然环保  
Natural environmental protection

GN 1049 T= 2.0 MM	GN 2276 转角 T= 2.0 MM	GN 2561 T= 1.5 MM
GN 8018 T= 1.8 MM	GN8118 T= 1.2 MM	
GN 1518 T= 1.0 MM	GN 9928 T= 1.5 MM	
GN 9938 T= 1.5 MM	GN 8098 T= 1.5 MM	
GN 1693 T= 1.2 MM	GN 1729 T= 1.0 MM	

GN 8088 T= 1.5 MM	GN 1521 T= 1.4 MM
GN 8168 T= 1.2 MM	GN 2131 T= 1.1 MM
GN 2106 T= 0.8 MM	GN 1577 T= 1.1 MM
GN 1271 T= * MM	GN 8108 T= 1.2 MM
GN 0256 T= 1.2 MM	GN 9998 T= 1.5 MM

GN 2611 T= 1.5 MM	GN 1298 T= 1.0 MM
GN 0847 T= 1.0 MM	GN 8068 T= 1.5 MM
GN 8078 T= 1.5 MM	GN 1448 T= 1.0 MM
GN 2999 T= 1.2 MM	GN 6035 T= 1.2 MM
GN 6039 T= 1.2 MM	GN 6074 T= 1.2 MM

GN 9978 T= 1.5 MM	GN 1123 T= 1.3 MM
GN 1321 T= 1.0 MM	GN 1334 T= 1.2 MM
GN 2232 T= 1.5 MM	GN 2251 T= 1.4 MM
GN 2255 T= 1.4 MM	GN 2307 T= 1.8 MM
GN 6070 T= 1.5 MM	GN 2216 T= 2.0 MM

GN 2470 T= 1.8 MM	GN 8998 T= 1.1 MM
GN 2580 T= 3.0 MM	GN 2318 T= 2.8 MM
GN 1621 T= 0.9 MM	GN 2584 T= 1.2 MM
GN 0716 T= 0.9 MM	GN 6027 T= 1.2 MM
GN 2483 T= 1.1 MM	GN 2369 T= 1.2 MM

GN2203 T= 1.2 MM	GN9958 T= 1.5 MM
GN9878 T= 1.5 MM	GN9888 T= 1.5 MM
GN6007 T= 1.5 MM	GN2350 T= 2.5 MM
GN2731 T= 2.0 MM	GN1736 T= 1.2 MM
GN2509 T= 1.0 MM	GN1531 T= 1.1 MM

GN1701 T= 1.8 MM	GN1771 T= 1.0 MM
GN8128 T= 2.0 MM	GN2316 T= 1.2 MM
GN2484 T= 1.1 MM	GN2373 T= 1.8 MM
GN1600 T= 1.8 MM	GN1725 T= 1.0 MM
GN1788 T= 1.5 MM	GN9988 T= 1.5 MM

GN1758 T=1.5 MM	GN8878 T=1.8 MM
GN8808 T=1.8 MM	GN9808 T=1.8 MM
GN2107 T=1.9 MM	GN1886 T=2.0 MM
GN1704 T=1.5 MM	GN1622 T=1.2 MM
GN2359 T=1.5 MM	GN2670 T=1.6 MM

GN2186 T=1.5 MM	GN2774 T=0.9 MM
GN2599 T=2.0 MM	GN9003 T=1.5 MM
GN9908 T=1.8 MM	GN2557 T=1.0 MM
	GN2556 T= 1.8 MM
GN1578 T=3.0 MM	GN1974 T=3.0 MM
GN9002 T=3.0 MM	GN2376 T=2.0 MM

GN9738 T=1.5 MM	GN1680 T=1.0 MM
GN0261 T=1.1 MM	GN1625 T=1.2 MM
GN2245 T=1.4 MM	GN2270 T=1.3 MM
GN2650 T=1.0 MM	GN2409 T=2.0 MM
GN2356 T=1.3 MM	GN2360 T=1.3 MM

GN2408 T=2.0 MM	GN2284 T=1.8 MM
GN9708 T=0.8 MM	GN2463 T=1.8 MM
GN1459 T=1.1 MM	GN1427 T=1.1 MM
GN2460 T=1.5 MM	
GN2419 T=1.5 MM	GN2460 GN2419

GN1773 T=1.2 MM	GN1386 T=1.8 MM
GN1606 T=2.0 MM	GN2108 T=1.8 MM
GN2683 T=1.35 MM	GN2559 T=0.9 MM
	GN2560 T=1.0 MM
GN 2612 T=2.2 MM	GN2645 T=1.3 MM
GN 2445 T=1.3 MM	GN6037 T=1.8 MM

GN2699 T=1.4 MM	GN2715 T=0.9 MM
GN2348 T=3.0 MM	GN2349 T=3.0 MM
GN2140 T=1.0 MM	GN8178 T=1.5 MM
GN8188 T=1.5 MM	GN2256 T=1.9 MM
GN2009 T=1.2 MM	

GN1768 T=1.2 MM	GN2650 T=1.0 MM
GN3496 T=1.0 MM	GN3496 T=1.0 MM
GN2010 T=1.4 MM	GN8038 T=1.0 MM
GN8198 T=1.0 MM	GN1326 T=1.0 MM
GN8008 T=1.3 MM	GN2419 T=1.5 MM
GN0591 T=1.5 MM	GN8138 T=1.2 MM

GN0271 T=1.3 MM	GN1312 T=1.3 MM
GN9838 T=1.3 MM	GN1283 T=1.3 MM
GN2135 T=2.2 MM	GN2134 T=1.5 MM
GN 9868 T=0.9 MM	GN1314 T=1.3 MM
GN 2074 T=1.3 MM	GN1313 T=1.3 MM



GN 8158 T= 1.2 MM	GN 9828 T= 1.2 MM
GN 9858 T= 1.0 MM	GN 8058 T= 1.3 MM
GN-JH001 T= 1.3 MM	GN2325 T= 1.3 MM
GN 9008 T= 1.9 MM	GN 1550 T= 1.0 MM
GN2030 T= 2.0 MM	GN1528 GN1529 T= 2.0 MM

GNTW-028 T= 1.7 MM	GN 1738 T= 1.5 MM
NTW-028 T= 1.7 MM	GN2191 T= 1.7 MM
GN8898 T= 1.8 MM	GN2492 T= 1.9 MM
GN6038 T= 1.8 MM	GN7208 T= 2.0 MM
GN 8028 T= 1.2 MM	GN2155 T= 1.5 MM

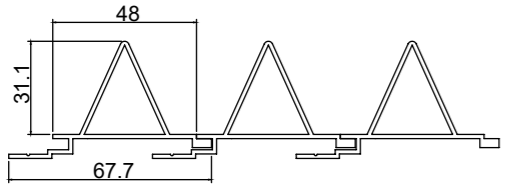
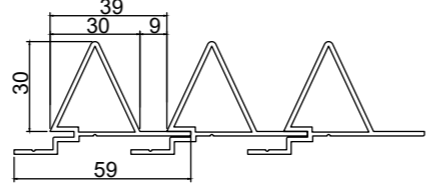
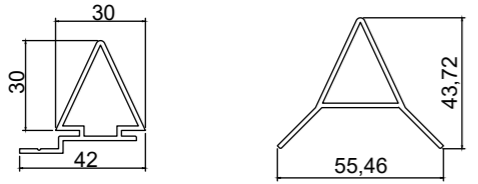
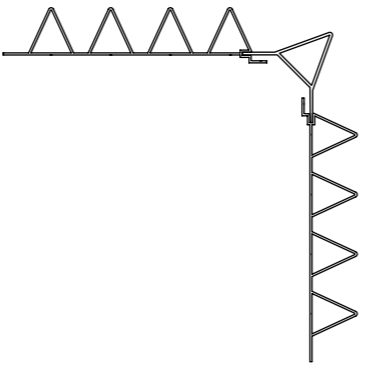
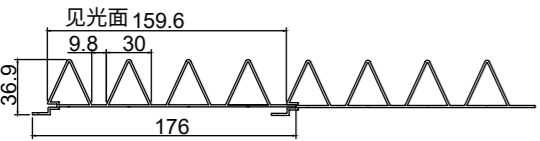
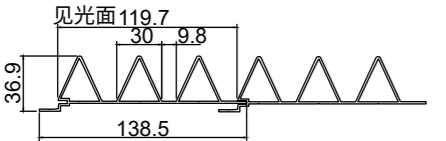
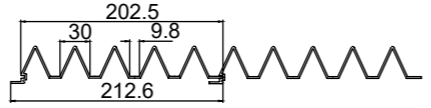
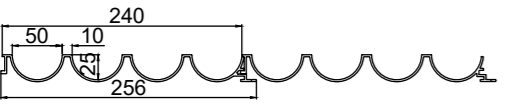
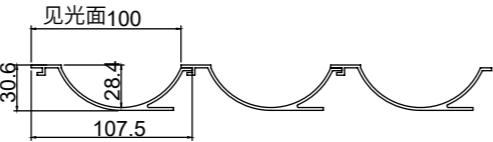

GN 2682 T= 1.8 MM	GN 1045 T= 2.0 MM
GN 1466 T= 2.0 MM	GN 2035 T= 2.5 MM
GN 1384 T= 1.2 MM	GN2156 T= 1.2 MM
GN 2473 T= 1.1 MM	GN 2382 T= 2.4 MM
GN 1246 T= 1.1 MM	GN 1212 T= 1.2 MM

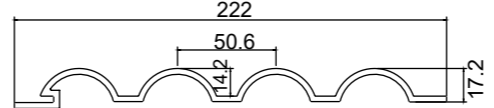
GN 1774 T= 1.5 MM	GN1774 GN1775 T= 1.2 MM
GN 1775 T= 1.5 MM	GN1775 GN1774 T= 1.2 MM
GN 1727 T= 1.5 MM	GN 9004 T= 1.5 MM
GN 9005 T= 2.5 MM	GN9004 GN9005 T= 1.5 MM T= 2.5 MM
GN 2367 T= 1.2 MM	GN 2368 T= 1.2 MM

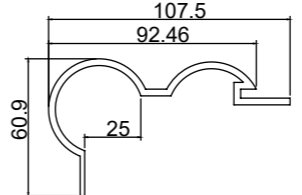
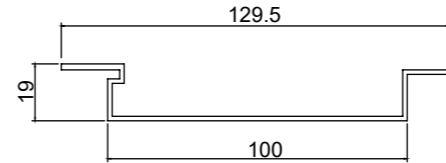
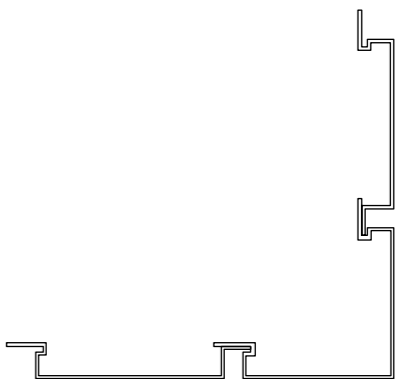
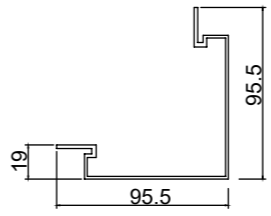
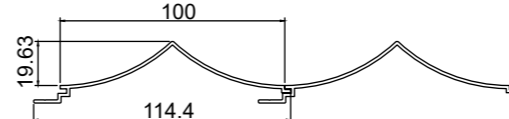
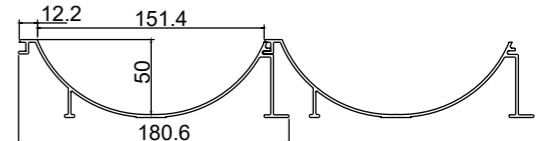
	
<p>GN 1747 T= 1.4 MM</p>	<p>GN 1128 T= 1.5 MM</p>
	
<p>GN 1129 T= 1.5 MM</p>	<p>GN 1130 T= 1.5 MM</p>
	
<p>GN 2018 T= 1.4 MM</p>	<p>GN2018      GN1130</p>
	
<p>GN 1108 T= 1.4 MM</p>	<p>GN 2174 T= 1.0 MM</p>
	
<p>GN 7007 T= 2.2 MM</p>	<p>GN 2698 T= 1.9 MM</p>

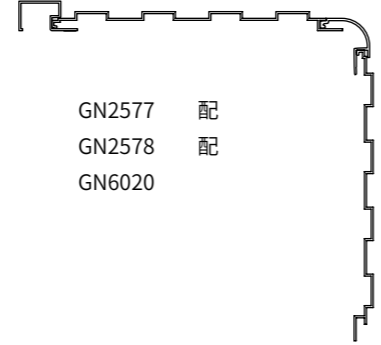
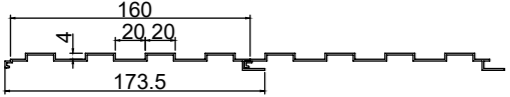
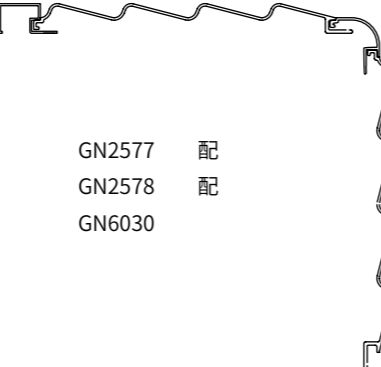
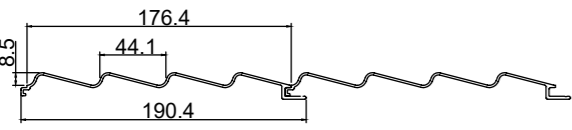
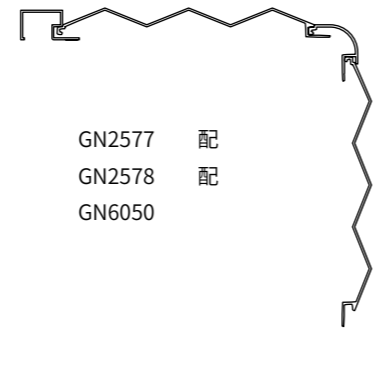
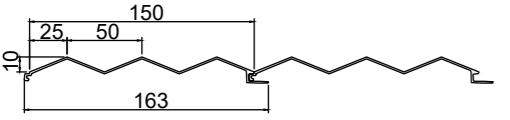
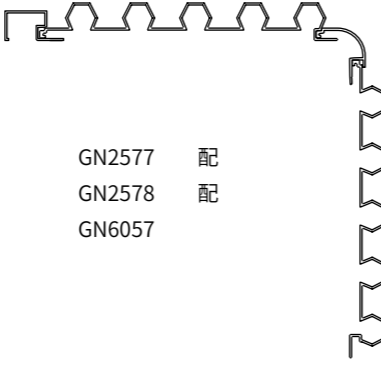
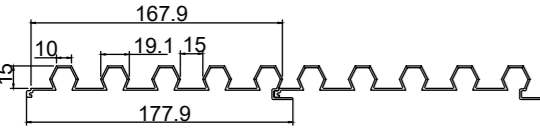
	
<p>GN 1681 T= 3.0 MM</p>	
	
<p>GN 1682 T= 3.0 MM</p>	<p>GN1681      GN1682</p>
	
<p>GN 2017 T= 2.0 MM</p>	
	
<p>GN 2019 T= 1.5 MM</p>	<p>GN2017      GN2019 2470</p>
	
<p>GN 1293 T= 1.4 MM</p>	<p>GN 7006 T= 2.2 MM</p>

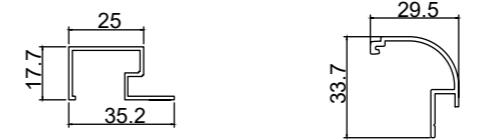
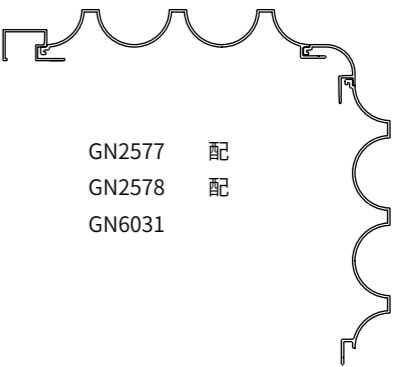
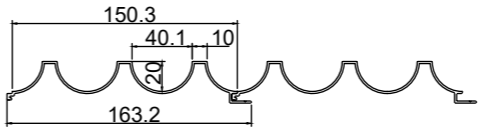
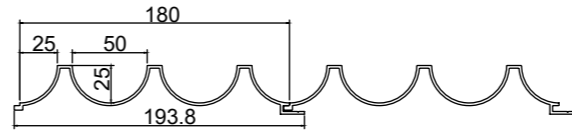
	 <p>GN2577 配 GN2578 配 GN6020</p>
<p>GN2577 T=1.2 MM</p> <p>GN2578 T=1.4 MM</p>	
	 <p>GN2577 配 GN2578 配 GN6030</p>
<p>GN6017 T=1.2 MM</p>	
	 <p>GN2577 配 GN2578 配 GN6050</p>
<p>GN6030 T=1.5 MM</p>	
	 <p>GN2577 配 GN2578 配 GN6057</p>
<p>GN6050 T=1.2 MM</p>	
	
<p>GN6057 T=1.2 MM</p>	

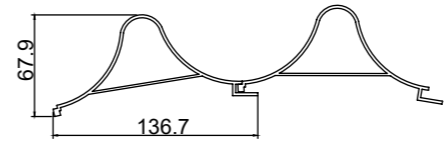
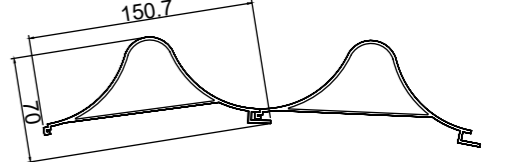
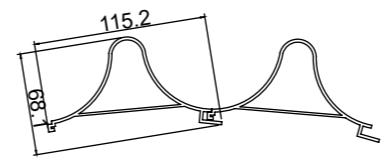
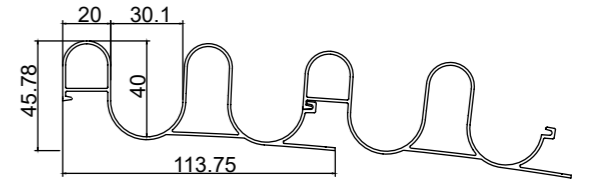
	 <p>GN2577 配 GN2578 配 GN6031</p>
<p>GN2577 T=1.2 MM</p> <p>GN2578 T=1.4 MM</p>	
	
<p>GN6031 T= 1.4 MM</p>	
	
<p>GN 8868 T= 1.8 MM</p>	<p>GN 2279 T= 1.2 MM</p>
	
<p>GN 2317 T= 2.0 MM</p>	<p>GN 2343 T= 2.0 MM</p>
	
<p>GN 2344 T= 2.0 MM</p>	<p>GN 2114 T= 1.2 MM</p>

GN6688 T=1.7 MM	GN2838 T=1.8 MM
GN2845 T=1.0 MM	GN2826 T=2.0 MM
GN2866 T=1.2 MM	GN2876 T=1.8 MM
GN2966 T=2.0 MM	GN2967 T=2.0 MM
GN2968 T=1.0 MM	GN2975 T=1.5 MM

GN2981 T=1.5 MM	GN2982 T=1.5 MM
GN3061 T=1.1 MM	GN3062 T=1.1 MM
GN3091 T=1.3 MM	GN3104 T=1.9 MM
GN3107 T=1.5 MM	GN3358 T=2.9 MM
GN3359 T=1.8 MM	GN3160 T=1.0 MM

GN3161 T=3.0 MM	GN3165 T=1.2 MM
GN3203 T=2.0 MM	GN3238 T=0.8 MM
GN3300 T=1.0 MM	GN3303 T=1.4 MM
GN3307 T=3.0 MM	GN3318 T=2.0 MM
GN3334 T=3.0 MM	GN3335 T=3.0 MM
	GN3337 T= MM

GN3387 T=1.4 MM	GN3436 T=1.8 MM
GN3437 T=2.0 MM	GN3438 T=2.0 MM
GN3442 T=1.2 MM	GN3443 T= MM
GN3445 T=2.0 MM	GN3450 T=0.9 MM
GN3459 T=1.2 MM	GN3470 T=2.5 MM







波浪板 - 长城系列 WAVE PLATE - GREAT WALL SERIES >>>



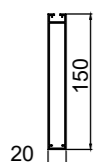

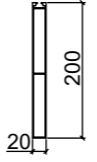
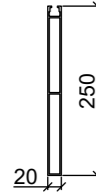
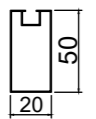
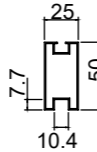
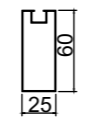
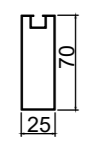

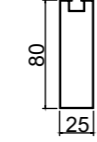
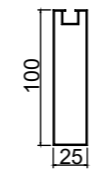
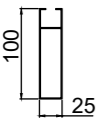
GN3474 T=3.0 MM	GN3475 T=3.0 MM
GN3490 T=1.0 MM	GN3503 T=1.8 MM

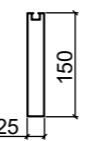
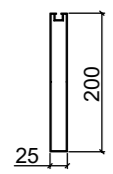
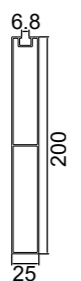
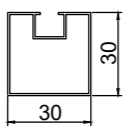
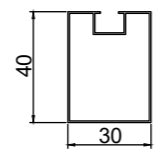
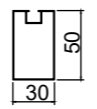

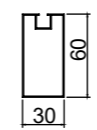
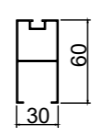
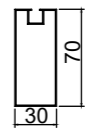
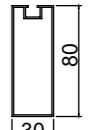
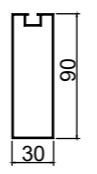
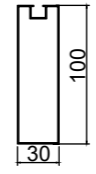
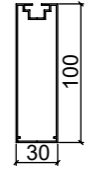
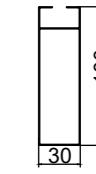
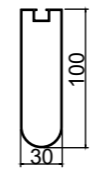



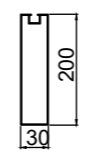
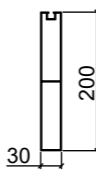
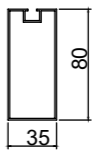

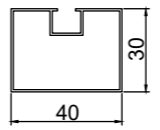
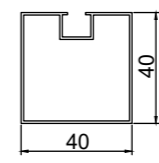
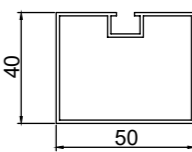
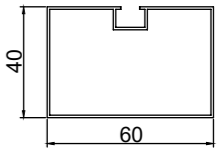

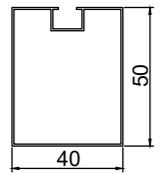
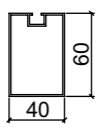
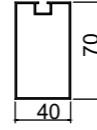
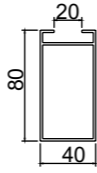
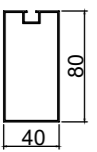
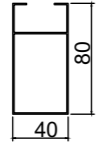
天花板系列 CEILING SERIES >>>

10 系列 			
GN 0760 T=0.7 MM	80X10TH T=0.7 MM		
15 系列 			
GN 0814 T=1.0 MM	GN 60X15TH T=1.1 1.8 MM	GN 0992 T=0.8 MM	GN 1444 T=1.2 1.5 MM
20 系列 			
GN 0926 T=1.2 MM	GN 40X20TH T=0.7/0.8/0.9/1.3 MM	GN 20X40TH T=0.8/1.0/1.3/1.5 MM	GN 50X20TH T=0.7/0.9/1.2/1.4 MM
GN2616 T=2.0 MM	GN 60X20TH T=0.8/1.0/1.2/1.3 MM	75X20TH T= 1.2 MM	GN80X20TH T=0.8/1.0/1.2 MM
GN 100x20TH T=0.8/0.9/1.0/1.2/1.4 MM	GN 120x20TH T=1.0/1.2/2.0 MM	GN2137 T= 1.0 MM	GN150X20TH T=0.9/1.0/1.2/1.4/1.5 MM

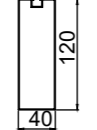
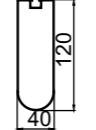
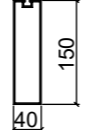
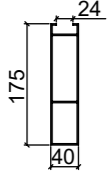
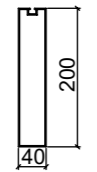
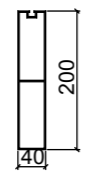
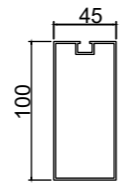
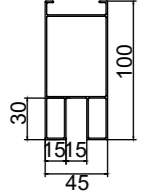
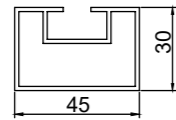
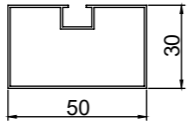
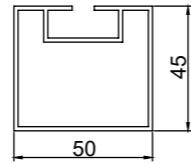
			
GN2617 T=1.5 MM	GN 180X20TH T=1.6 MM	GN 200X20TH T= 1.5/1.6/2.0 MM	GN 200X20TH T=1.3/1.5 MM
	25 系列 		
GN 0837 T= 2.2 MM	GN 50X25TH T=0.7/0.8/0.9/1.0/1.1/1.2/1.4 MM	GN 1938 T= 1.0 MM	GN 60X25TH T= 0.7/1.0/1.2 MM
			
GN 70X25TH T=0.8/0.9/1.2 MM	GN 75X25TH T= 0.8/0.9/1.0/1.2 MM	GN 80X25TH T= 0.8/0.9/1.0/1.2/1.4MM	GN 100X25 T=0.8/0.9/1.0/1.2/1.5/1.8/2.0MM
			
GN 1483 T=1.0/1.2MM	GN1893 T=1.0 MM	GN 120X25TH T=0.8/0.9/1.1/1.2/1.5/1.8MM	GN 150X25TH T=0.8/1.0/1.3/1.5/1.8 MM
	6.8 	30 系列 	
GN 200X25TH T=1.5/1.6/1.9/2.0 MM	200X25TH 带筋 T= 1.3 MM	GN 30X30TH T= 0.8/1.0/1.2/1.5 MM	GN 40X30TH T=0.7/0.8/1.0/1.2/1.4/1.8MM
			
GN 50X30TH T=0.6/0.8/0.9/1.0/1.2/1.4 MM			

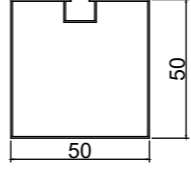
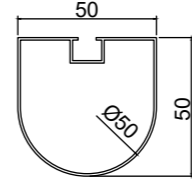
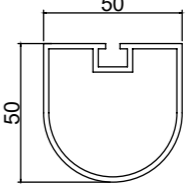
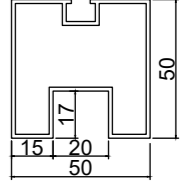
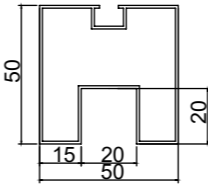
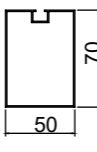
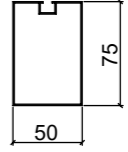
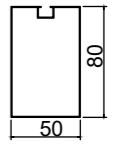
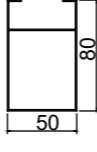
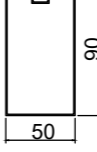
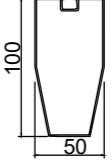
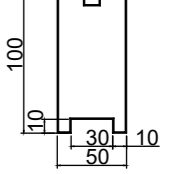
			
GN 60X30 T=0.7/0.8/0.9/1.0/1.2/1.5/1.8 MM	LC-GN0745 T=0.8 MM	GN 70X30 T=0.8/0.9/1.0/1.2/1.5/1.8 MM	80X30TH T= 0.7/0.8/1.0/1.2/1.5/1.8/2.0 MM
			
GN 90X30TH T=0.8/0.9/1.2/1.5 MM	GN 100X30TH T=0.7/0.8/0.9/1.0/1.2 1.5/2.0/2.4 MM	GN 1574 T=1.2 MM	GN 0103 T=1.0/1.2MM
			
GN 1591 T=1.0 MM	GN 0758 T=0.8/0.9/1.0/1.2/1.5/1.8 MM	GN2714 T=1.1 MM	GN 150X30TH T=0.8/1.0/1.2/1.5/1.8/1.9/2.5MM
		35 系列 	
GN 200X30TH T=1.5/1.8/2.0 MM	GN 200X30TH T= 1.3/1.6 MM	GN 80X35TH T=1.2 MM	GN 100X35TH T= 0.8/1.0/1.2 MM
40 系列 			
GN 30X40TH T=0.8/1.0/1.2MM	GN 40X40TH T=0.7/0.8/0.9/1.0/1.2/1.5/1.8MM	40X50TH T= 0.8/1.0/1.2 MM	40X60TH T= 0.9/1.1 MM

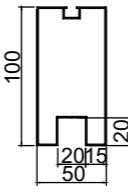
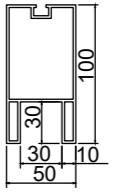
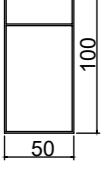
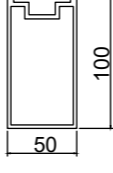
			
GN 50X40TH T=0.7/0.9/1.0/1.2/1.5/1.8/3.0MM	60X40TH T=0.8/1.0/1.2/1.3/1.8 MM	70X40TH T=0.8/0.9/1.0/1.2/1.5 MM	GN2305 T= 1.7 MM
			
80X40TH T= 0.7/0.8/0.9/1.0/1.1/1.3 1.5/1.8 MM	GN 1482 T=1.0/1.2 MM	90X40TH T=0.8/0.9/1.0/1.1/1.2 /1.5/1.8MM	100X40TH T= 0.8/0.9/1.0/1.1/1.2/1.5 1.8/2.0MM
			
GN 1485 T=1.0/1.2 MM	120X40TH T=0.8/0.9/1.0/1.1/1.2/1.5/ 1.8/2.0 MM	GN 2011 T= 1.1 MM	150X40TH T=0.9/1.1/1.2/1.5/1.8/2.0 MM
			45 系列 
GN 1991 T=2.0 MM	200X40TH T= 1.5/1.8/2.0/2.5 MM	200X40TH T=1.3/ 1.5 MM	GN 100X45TH T= 1.4 MM
		50 系列 	
GN2277 T=1.1 MM	30X45TH T= 1.5 MM	GN-30X50 T= 0.8/1.0/1.2/1.4 MM	45X50TH T= 1.5 MM

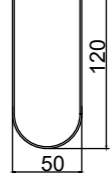
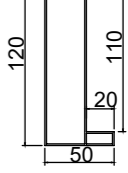
			
50X50TH T=0.6/0.7/0.8/0.9/1.0/1.1/1.2 1.5/1.8/2.0/2.4/3.0MM	GN 2012 T= 0.9 MM	GN2558 T= 1.9 MM	GN2740 T= 1.4 MM
			
GN 2249 T= 1.0/2.5 MM	70X50TH T= 0.8/0.9/1.0/1.2/1.5/1.8 MM	75X50TH T= 1.0 MM	GN 80X50TH T=0.7/0.8/1.0/1.2/1.5/1.8/2.0 MM
			
GN 1487 T= 1.0 MM	GN 90X50TH T= 0.8/0.9/1.0/1.1/1.2/1.5 1.8/2.0 MM	GN 2333 T= 1.2 MM	GN 2304 T=0.9 MM
			
100X50TH T= 0.7/0.8/0.9/1.0/1.1/1.2 1.5/1.8/2.0MM	GN 2250 T= 1.0 MM	GN 0819 T= 1.9 MM	GN1486 T= 1.0/1.2/1.5 MM
			
GN2750 T= 2.5 MM	GN 120X50TH T= 0.9/1.0/1.2/1.3/1.5/1.8 2.0/2.4 MM	GN2013 T= 1.2 MM	GN2223 T= 1.2 MM

150X50TH T= 0.9/1.0/1.1/1.2/1.3/1.5 1.8/2.0/2.5 MM	GN 1588 T= 1.9 MM	GN 2749 T=2.5 MM	GN 2014 T= 1.3 MM
GN 0857 T= 2.0 MM	GN 1488 T= 1.2/1.5 MM	200X50TH T= 1.5/1.8/2.0/2.5 MM	200X50TH 带筋 T=1.3 MM
250X50TH T= 2.2/2.3/2.5 MM	GN 30X60 T= 0.8/1.0/1.2 MM	60X60TH T= 0.8/0.9/1.0/1.2/1.5/1.8 MM	GN 1684 T=1.2 MM
GN 1500 T= 0.8/0.9 MM	80X60TH T=1.0/1.2/1.3/1.4/1.8 MM	GN 1684 T= 1.2 MM	GN 1789 T= 1.2 MM
GN 0649 T= 1.2 MM	100X60TH T=1.0/1.1/1.4/1.8/2.0/2.4 MM	GN 120X60 T=1.1/1.2/1.5/1.8/2.0/2.4 MM	GN 2183 T= 1.8 MM

GN 2400 T= 1.4 MM	150X60TH T=1.2/1.5/1.6/1.8/2.0 MM	GN 1058 T= 1.5 MM	160X60TH T= 1.5/1.6/1.8/2.0 MM
		70-75 系列	
200X60TH T= 1.6/1.8/2.0 MM	GN 0997 T= 1.9 MM		
		80 系列	
GN 100x75TH T=1.2 MM	GN 150x75TH T= 1.5/1.8 MM		
GN 50X80TH T= 0.8/1.0/1.2/1.5/2.0 MM	GN 60X80TH T= 0.9/1.0/1.2/1.5 MM	GN 80X80 T=0.9/1.0/1.2/1.3/1.8/2.0 MM	GN2760 T= 1.1 MM
100X80TH T=1.0/1.1/1.5/1.8/2.0 MM	GN 120X80TH T=1.2/1.4/1.8/2.0MM	GN 1240 T=1.3 MM	GN 150X80TH T= 1.5/1.8/2.0/2.5 MM

		100 系列 	
200X80TH T= 1.8/2.0 MM	250X80TH T= 2.5 MM	GN 50X90TH T= 1.0/1.2 MM	GN 30X100TH T=0.9/1.0/1.1 MM
GN 50X100TH T=1.0/1.2/1.5/1.8 MM	GN 70X100TH T=1.1/1.2 MM	GN 100X100 TH T=1.2/1.5/1.8/2.0 MM	JJ-GN1328 T=1.5 MM
GN2292 T= 1.5/1.8 MM	GN 1472 T=3.0 MM	GN 0869 T=1.9 MM	150X100TH T=1.8/2.0/2.5 MM
GN2775 T= 2.2 MM	GN2136 T= 3.0 MM	200X100TH T=1.5/1.8/2.0/2.2/2.5 MM	250X100TH T= 2.3 MM
			150 系列 
300X100TH T= 2.8 MM	GN 50X120TH T=1.2/1.5MM	GN 1059 T= 1.8 MM	GN 50X150TH T= 1.3/1.8 MM

GN 100X120TH T= 1.6 MM	100X150TH T= 2.0/2.5 MM	GN150X150TH T=2.0/2.2 MM	GN50X200TH T= 1.6 MM
200 系列 	250 系列 		
GN 100X200TH T= 2.0/2.2 MM	GN 100X250TH T= 2.5 MM	GN2497 T=0.9 MM	GN2138 T= 1.2 /1.8 MM
GN 0265 T= 0.6 MM	GN2552 T=1.5 MM	GN30X50UC T=0.6/0.7/0.9 MM	GN1661 T= 1.8 MM
GN60X40UC T= 0.9 MM	GN70X50UC T= 2.0 MM	GN80X40UC T= 1.2/1.4/1.8 MM	GN80X50UC T= 1.2/1.4/1.8 MM
GN100X40UC T= 1.2/1.4/1.8 MM	GN2867 T=1.8 MM	GN2796 T=1.1 MM	100X30UC T= 1.2 /1.4/1.8 MM



GN25TH T=0.8/1.0 MM	GN30 T=0.7/0.8/0.9/1.0 MM	GN30X0.7ACTH T=0.7 MM	GN 1369 T=1.5 MM
GN 1412 T=1.0 MM	GN40X0.7ACTH T=0.7 MM	GN40X0.8TH T=0.7/0.8/0.9/1.0/1.1/1.2/1.4 MM	GN 1370 T=1.2 MM

GN2161 T=0.7 MM	GN1244 T=1.1 MM	GN45ACTH T=1.0 MM	GN50YGTH T=0.7/0.8/0.9/1.0/1.1/1.2/1.4/1.8 MM
GN50ACTH T=0.7/0.8/0.9/1.0/1.1/1.2/1.4 MM	GN2766 T=0.8/1.6 MM	GN60TH T=0.8/0.9/1.0/1.2/1.4 MM	GN60ACTH T=0.8/1.0/1.2 MM
GN 60ACTH T=0.8 MM	GN 70TH T=1.0/1.2/1.4 MM	GN 2059 T=1.2 MM	GN 80YGTH T=0.9/1.2/1.4 MM
GN80ACTH T=0.9/1.0/1.2/1.4 MM	GN 90TH T=1.0/1.2 MM	GN 0795 T=1.2/1.3/1.4/1.8 MM	GN 120TH T=1.8 MM
GN2472 T=1.9 MM	GN2477 T=1.8 MM	GN2661 T=1.0 MM	GN2059 T=1.2 MM

GN 150TH T= 2.2 MM	GN 180TH T= 2.3 MM	GN 200TH T= 2.5 MM	GN2271 T= 1.5 MM
六边框系列 			方管吊件 
GN 1231 T=0.6 MM	GN 1232 T=1.2 MM		GN2772 T= 2.0 MM
GN2873 T= 0.9 MM	GN2874 T=1.0 MM	GN2796 T= 1.1 MM	GN2820 T=3.0 MM
100X15TH T=1.8 MM	60X15TH T=1.8 MM	GN2855 T=0.8 MM	GN2862 T=1.8 MM
GN2867 T=1.85 MM	GN2884 T=1.5 MM	GN2885 T=1.0 MM	100X120TH T=1.6 MM

BULLET SERIES  
子弹头系列  
>>>

GN 1576ZDT T=0.9/1.1 MM	GN 100X40ZDT T= 0.9/1.1 MM	GN 100X50ZDT T= 1.0 MM
1:2 		
GN 120X30ZDT T= 1.2 MM	GN 2238ZDT T= 1.2 MM	GN 180X40ZDT T= 1.6 MM
GN 120X50ZDT T= 1.2 MM	GN 150X50ZDT T= 1.5 MM	GN 0551 T=1.2 MM
GN 200X50ZDT T= 2.0 MM	GN 250X60ZDT T= 2.5 MM	GN 150X25ZDT T= 1.5 MM

子弹头系列 BULLET SERIES >>>

GN100X25X0.7TH T= 0.7 MM	GN2166 T= 2.0 MM	GN 0385 T=0.8 MM
GN 1500 T= 0.8 0.9 1.0 MM	GN2113 T= 2.5 MM	GN 1270 T= 1.2 MM
2:1 		
GN 0770 T= 1.1 MM	GN 1571 T= 1.2 MM	GN 1549 T= 1.2 MM
GN 1026 T= 1.2 MM	GNDG004 T= 1.5 MM	GN2953 T= 0.9 MM
GN 0862 T=4.5 MM	GN 0863 T=4.5 MM	

滴水挂片系列 DRIP HANGING PIECE SERIES >>>

GN 0062 T=0.7/0.9/1.1 MM	GN 1717 T= 0.8 MM	GN F01 T=0.9/1.0/1.1/1.2MM
	1:2 	
GN150X25DS T= 1.3 MM	GN 0702 配 GN 0703 T= 1.8 MM	
GN200X50DS T= 2.0 MM	GN250X60DS T= 2.5 MM	GN150X35DS T= 1.4 MM
GN80X18X0.8TH T= 0.8/0.9/1.1 MM	GN100X20X0.8TH T= 0.8/0.9/1.1/1.2 MM	GN100X25X0.8TH T= 0.8/0.9/1.1/1.2/1.4 MM
GN 150X50DS T= 1.4 MM		



GN 0084 T=0.9 MM	GN 0092 T=1.2 MM	GN 0161 T=1.1 MM	GN 0162 T=0.9 MM
GN 0209 T=0.7 MM	GN 0474 T=0.7 MM	GN 0983 T=0.9 MM	GN 0269 T=0.9 MM

GN 1037 T=0.8 MM	75x1.2 百叶片 T=0.7/1.0/1.2 MM	GN 1170 T=0.8 MM	GN1290 T=2.2 MM
GN 1439 T=1.2 MM	GN 2049 T=1.8 MM	GN 0420 T=0.4 MM	GN 0498 T=0.4 MM
ZY-018 T=0.8 MM	GN 1132 T=0.9 MM	GN 1548 T=0.4 MM	GN 1441 T=0.4 MM
GN2878 T=1.2 MM	GN 0882 T=0.9 MM	GN 1329 T=1.0 MM	GN 1464 T=1.0 MM
GN 1463 T=1.1 MM	GN 1462 T=1.2 MM	GN 1221 T=1.7 MM	GN 6608 T=1.7 MM

GN 1137 T=2.0 MM	GN 6018 T=1.7 MM	GN 6098 T=2.0 MM	GN 6628 T=2.5 MM
GN 6618 T=1.7 MM	GN 1265 T=2.2 MM	GN 2701 T=2.0 MM	GN 6708 T=2.3 MM
GN 6698 T=2.3 MM	GN 6638 T=2.5 MM	FC-BY086 T=3.0 MM	GN 6658 T=2.5 MM
GN 6668 T=2.5 MM	GN 0977 T=1.4 MM	GN 0539 T=2.0 MM	GN 2173 T=1.0 MM
GN 2296 T=0.9 MM	GN 0965 T=2.8 MM	GN 2596 T=3.0 MM	GN 0667 T=1.1 MM

GN 1138 T=3.0 MM	GN 1593 T=1.2 MM	GN 1616 T=1.5 MM	GN 1395 T=1.0 MM
GN 2794 T=1.4 MM	GN 2688 T=1.4 MM	GN 0845 T=2.0 MM	GN 0405 T=1.3 MM
GN 0406 T=1.8 MM	GN 2585 T=1.2 MM	GN 2586 T=1.2 MM	GN 7008 T=1.4 MM
GN 7009 T=1.4 MM	GN 1523 T=1.5 MM	GN 2662 T=1.4 MM	GN 1264 T=2.0 MM
GN 2641 T=1.2 MM	GN 2642 T=1.2 MM	JJ-GN1332 T=1.4 MM	34 工字 T=1.0 MM

百叶系列 LOUVER SERIES >>>

JJ-GN1421 T= 0.75 MM	38 工字 T= 1.2 MM	58 工字 T= 1.4 MM	GN3059 T= 1.0 MM

ALUMINUM ART SERIES  
铝艺系列 >>>



铝艺系列 ALUMINUM ART SERIES >>>

GN 0932 T= 1.4 MM	GN 1440 T= 2.5 MM	GN 1038 T= 1.8 MM	GN 1171 T= 2.0 MM
GN 1267 T= 2.0 MM	GN 1143 T= 2.0 MM	GN 0968 T= 2.0 MM	GN 0933 T= 2.0 MM
GN 1397 T= 3.0 MM	JJ-GN1743 T= 2.0 MM	GN 0966 T= 1.9 MM	GN 1152 T= 1.6 MM
GN 1191 T= 2.0 MM	GN 1140 T= 2.0 MM	GN0793 T= 2.5 MM	GN 0889 T= 1.4/1.6/2.0 MM
GN 2044 T= 1.4 MM	GN 1352 T= 2.5 MM	GN 1972 T= 2.0 MM	GN 0962 T= 1.8 MM

GN 0725 T=1.2 MM	GN 0774 T= 2.0 MM	GN 0805 T= 2.0 MM	GN 0809 T=2.1 MM
GN 1581 T= 3.0 MM	GN 1733 T= 1.8 MM	GN2205 T= 3.5 MM	JJ-GN1513 T= 2.5 MM
GN2201 T= 2.9 MM	GN2187 T= 2.0 MM	GN 1091 T= 1.4 MM	GN 1739 T= 2.0 2.9 MM
GN2730 T=2.3 MM	GN2220 T= 3.0 MM	GN2506 T=1.5 MM	MH-GN0783 T= 3.0 MM
GN7002 T= 2.0 MM	GN7003 T= 2.0 MM	GN7004 T= 2.0 MM	GN7005 T= 2.0 MM

JJ-GN1086 T= 1.3 MM	JJ-GN1064 T= 1.5 MM	JJ-GN1065 T= 1.5 MM	JJ-GN1069 T= 1.5 MM
GN2711 T=1.5 MM	GN2337 T= 5.0 MM	GN2331 T= 2.0 MM	GN2720 T=1.5 MM
GN2721 T=1.5 MM	GN 2047 T= 2.0 MM	GN2204 T= 3.5 MM	GN2600 T=2.0 MM
GN2308 T= 2.7 MM	GN 1494 T= 1.7 MM	GN2651 T= 1.0 MM	GN2718 T= 2.0 MM
GN2709 T= 2.9 MM	GN 0773 T= 1.5 MM	GN 1003 T= 1.5 MM	GN 1892 T= 2.3 MM

GN 0806 T=2.0MM	GN2573 T=1.4 MM	GN2574 T=2.0 MM	GN2659 T=2.0 MM
GN2735 T= 0.6 MM	GN2754 T= 1.0 MM	GN 1941 T= 1.4 MM	GN 1032 T= 1.5/1.8/2.0 MM
GN 1082 T=1.5 MM	GN 1083 T=2.0 MM	GN 1659 T= 2.0 MM	GN 2572 T=2.0 MM
GN 1159 T= 1.0 MM	GN 1139 T= 1.9 MM	GN2569 T= 0.9 MM	GN 0764 T= 1.0 MM
GN 2644 T= 1.8 MM	GN 1611 T= 2.5 MM	GN 1237 T= 0.8 MM	GN 1794 T= 1.4 MM

GN 1868 T=0.8 MM	GN 1395 T= 1.2 MM	XQ-ZH04-GN1245 T= 0.9 MM	GN 2717 T= 2.0 MM
GN 0873 T= 2.0 MM	GN 0726 T= 0.9 MM	GN0761 T= 2.0 MM	GN 0835 T= 2.5 MM
GN1079 T=1.9 MM	GN 1213 T=5.0 MM	GN 0765 T=2.0 MM	GN 0766 T=2.0 MM
GN 1380 T= MM	GN 1512 T= 0.7 MM	GN 1369 T= 1.5 MM	GN 1965 T= 3.0 MM
GN 1623 T= MM	GN-Y036 T= 1.0 MM	GN 1381 T= MM	GN 1379 T= MM

GN 1076 T=1.5 MM	GN2253 T=2.1 MM	GN2274 T=1.5 MM	GN 1937 T=0.9 MM
GN 0882 T=0.9 MM	GN 0883 T=1.0 MM	GN 1116 T= MM	GN 1318 T=1.5 MM
GN 1971 T=0.8 MM	GN 1490 T=0.7 MM	GN 1407 T=2.0 MM	GN 1718 T=0.9 MM
GN 1085 T=2.3 MM	A-11090 T=2.8 MM	GN-Hi016 T=3.0 MM	GN 1072 T=3.0 MM
GN-Hi015 T=2.1 MM	GN 1277 T=1.5/2.0 MM	GN 1066 T=2.0 MM	GN 1061 T=2.7 MM

GN-Hi010 T=2.8 MM	GN 1428 T=1.4 MM	GN 1192 T=2.0 MM	GN 1009 T=1.2 MM
GN 0727 T=2.0 MM	GN 1364 T=4.0 MM	GN 1124 T=2.4 MM	JJ-GN1071 T=3.0 MM
JJ-GN1275 T=2.7 MM	JJ-GN1276 T=3.0 MM	GN 1135 T=1.5 MM	GN 1136 T=1.5 MM
GN2354 T=1.2 MM	GN2355 T=1.2 MM	GN 1363 T=4.3 MM	GN 1354 T=2.2 MM
GN 1185 T=1.1 MM	GN-Hi001 T=2.4 MM	GN2079 T=1.4 MM	GN 2068 T=1.4 MM

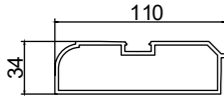
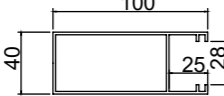
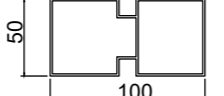
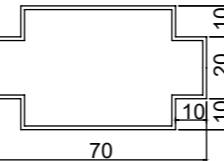
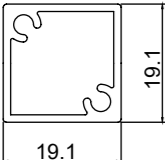
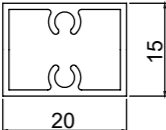
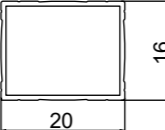
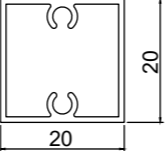
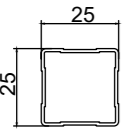
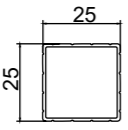
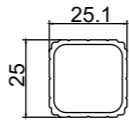
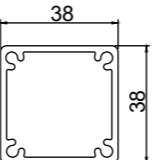
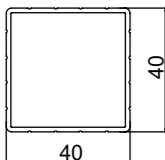
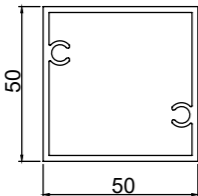
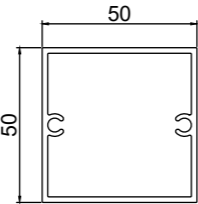
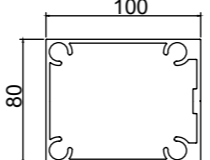
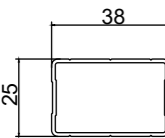
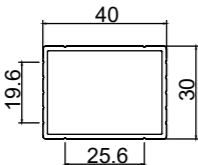
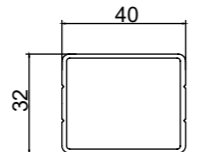
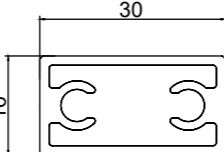
			
GN 1062 T=2.4 MM	GN 1854 T=1.7 MM	GN 1148 T=1.4 MM	GN 1997 T=1.2 MM
			
GN 2121 T=1.2 MM	GN 2053 T=1.0 MM	GN 1014 T=0.8 MM	GN 20B T=0.9 MM
			
GN 1149 T=1.0 MM	GN 1077 T=1.0 MM	GN 1078 T=1.5 MM	GN 2300 T=2.0 MM
			
GN 1080 T=1.5 MM	GN 2334 T=1.9 MM	GN 2540 T=1.8 MM	GN 2372 T=2.5 MM
			
GN 1151 T=1.2 MM	GN 1081 T=1.5 MM	GN 1411 T=1.3 MM	GN 1564 T=1.5 MM

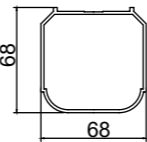
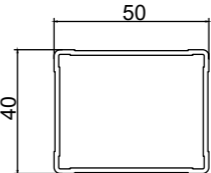
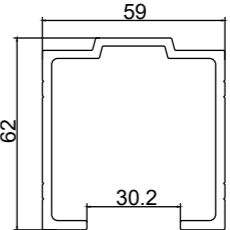
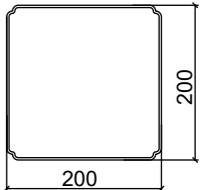
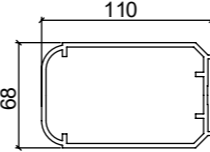
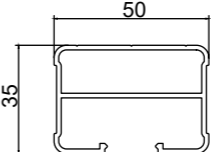
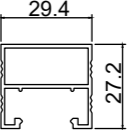
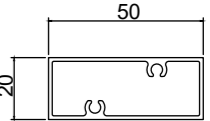
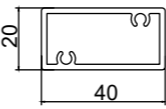
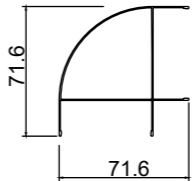
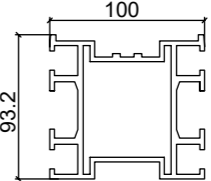
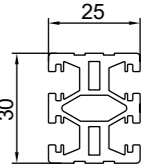
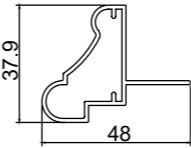
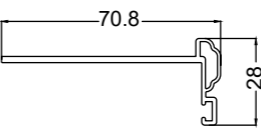
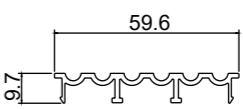
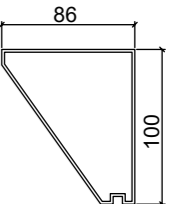
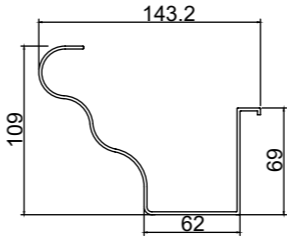
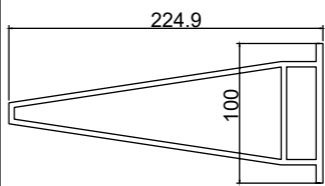
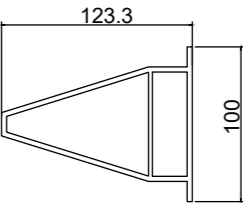
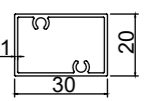
			
GN 1073 T=2.0 MM	GN 1150 T=1.5 MM	GN 1278 T=3.0 MM	GN 1010 T=3.0 MM
			
GN 1068 T=2.9 MM	GN 1193 T=1.5 MM	GN 0713 T=1.2 MM	GN 1331 T=1.2 MM
			
GN 1820 T=1.8 MM	GN 1174 T=0.7 MM	GN 1304 T= MM	GN 1303 T= MM
			
GN 1084 T=1.3 MM	GN 1279 T=2.0 MM	GN Hi005 T=1.5 MM	GN 1324 T=1.8 MM
			
GN 1060 T=2.0 MM	GN 0864 T=3.9 MM	GN 0859 T=3.3 MM	GN 3059 T=1.0 MM

组合管系列 COMBINED PIPE SERIES >>>

GN2439 配 GN2440 盖 	GN2085 配 GN2086 盖 	GN1454 配 GN1453 盖 	GN1195 配 GN1196 盖 				
GN 2439 T= 1.2 MM	GN 2440 T= 1.0 MM	GN 2085 T= 2.0 MM	GN 2086 T= 2.0 MM	GN 1454 T= 1.5 MM	GN 1453 T= 1.5 MM	GN 1195 T= 0.8 MM	GN 1196 T= 0.8 MM
GN2597 配 GN2598 盖 	GN1301 配 GN1302 盖 	GN0832 配 GN0833 盖 	GN1629 配 GN3781 盖 				
GN 2597 T= 1.2 MM	GN 2598 T= 0.8 MM	GN 1301 T= 1.2 MM	GN 1302 T= 1.2 MM	GN 0832 T= 1.5 MM	GN 0833 T= 1.2 MM	GN 1629 T= 0.9 MM	GN 3781 T= 0.9 MM
GN1372 配 GN1373 盖 	GN2562 配 GN2563 盖 	GN1401 配 GN1402 盖 	GN1403 配 GN1402 盖 				
GN 1372 T= 0.9 MM	GN 1373 T= 0.9 MM	GN 2562 T= 0.6 MM	GN 2563 T= 0.8 MM	GN 1401 T= 1.2 MM	GN 1402 T= 1.2 MM	GN 1403 T= 1.2 MM	GN 1402 T= 1.2 MM
GN9801 配 9802 盖 	GN1631 配 GN3781 盖 	GN1046 配 GN1047 盖 	GN1676 配 GN1677 盖 				
GN 9801 T= 1.0 MM	GN 9802 T= 0.9 MM	GN 1631 T= 1.0 MM	GN 3781 T= 0.9 MM	GN 1046 T= 1.5 MM	GN 1047 T= 1.5 MM	GN 1676 T= 1.8 MM	GN 1677 T= 1.8 MM
GN1664 配 GN1665 盖 	GN1780 配 GN1779 盖 	GN9809 配 GN1665 盖 	GN0948 配 GN0949 盖 				
GN 1664 T= 0.9 MM	GN 1665 T= 0.9 MM	GN 1780 T= 1.8 MM	GN 1779 T= 1.8 MM	GN 9809 T= 1.0 MM	GN 1665 T= 0.9 MM	GN 0948 T= 1.2 MM	GN 0949 T= 1.0 MM

组合管系列 COMBINED PIPE SERIES >>>

GN9811 配 0949 盖 	GN2406 配 2407 盖 	GN2722 配 0949 盖 	GN2608 配 2609 盖 				
GN 9811 T= 1.0 MM	GN 0949 T= 1.0 MM	GN 2406 T= 1.0 1.5 MM	GN 2407 T= 1.6 MM	GN 2722 T= 1.4 MM	GN 0949 T= 1.0 MM	GN 2608 T= 1.2 MM	GN 2609 T= 1.2 MM
GN9813 配 0949 盖 	GN9814 配 0949 盖 	GN9815 配 0949 盖 	GN9817 配 GN0949 盖 				
GN 9813 T= 1.0 MM	GN 0949 T= 1.0 MM	GN 9814 T= 1.2 MM	GN 0949 T= 1.0 MM	GN 9815 T= 1.2 MM	GN 0949 T= 1.0 MM	GN 9817 T= 1.4 MM	GN 0949 T= 1.0 MM
GN2404 配 2403 盖 	GN2576 配 0949 盖 	GN9821 配 GN9820 盖 	GN1286 配 1285 盖 				
GN 2404 T= 1.7 MM	GN 2403 T= 1.7 MM	GN 2576 T= 1.5 MM	GN 0949 T= 1.0 MM	GN 9821 T= 1.8 MM	GN 9820 T= 1.6 MM	GN 1286 T= 1.0 MM	GN 1285 T= 1.0 MM
GN1284 配 GN1285 盖 	GN2686 配 GN2687 盖 	GN1404 配 GN1405 盖 	GN1296 配 GN1295 盖 				
GN 1284 T= 1.0 MM	GN 1285 T= 1.0 MM	GN 2686 T= 1.8 MM	GN 2687 T= 0.8 MM	GN 1404 T= 1.2 MM	GN 1405 T= 1.2 MM	GN 1296 T= 1.9 MM	GN 1295 T= 1.0 MM
GN9827 配 GN1285 盖 	GN1636 配 GN1405 盖 	GN1594 配 GN1405 盖 	GN1294 配 GN1295 盖 				
GN 9827 T= 1.0 MM	GN 1285 T= 1.0 MM	GN 1636 T= 1.0 MM	GN 1405 T= 1.2 MM	GN 1594 T= 1.2 MM	GN 1405 T= 1.2 MM	GN 1294 T= 1.9 MM	GN 1295 T= 1.0 MM

组合管系列 COMBINED PIPE SERIES >>>

GN9833 配 9836A 盖 	GN9835 配 9836A 盖 	GN9837 配 9836A 盖 	GN9839 配 9836A 盖 				
GN 9833 T=1.2 MM	GN 9836A T=1.4 MM	GN 9835 T=1.4 MM	GN 9836A T=1.4 MM	GN 9837 T=1.4 MM	GN 9836A T=1.4 MM	GN 9839 T=1.8 MM	GN 9836A T=1.4 MM
GN9841 配 9836A 盖 	GN1469 配 GN1470 盖 	GN2582 配 GN2581 盖 	GN1209 配 GN1210 盖 				
GN 9841 T=1.8 MM	GN 9836A T=1.4 MM	GN 1469 T=1.2 MM	GN 1470 T=1.2 MM	GN 2582 T=2.0 MM	GN 2581 T=2.0 MM	GN 1209 T=1.3 MM	GN 1210 T=1.3 MM
GN0942 配 GN1210 盖 	GN1843 配 GN1844 盖 	GN2091 配 GN2092 盖 	GN2606 配 GN2607 盖 				
GN 0942 T=1.5 MM	GN 1210 T=1.3 MM	GN 1843 T=0.8 MM	GN 1844 T=0.9 MM	GN 2091 T=0.9 MM	GN 2092 T=0.9 MM	GN2606 T=1.0 MM	GN 2607 T=1.0 MM
GN9845 配 1968 盖 	GN9846 配 1968 盖 	GN0924 配 GN0925 盖 	GN1358 配 GN1359 盖 				
GN 9845 T=1.0 MM	GN 1968 T=1.2 MM	GN 9846 T=1.0 MM	GN 1968 T=1.2 MM	GN 0924 T=1.5 MM	GN 0925 T=1.5 MM	GN 1358 T=1.1 MM	GN 1359 T=1.3 MM
GN1638 配 GN1210 盖 	GN1967 配 GN1968 盖 	GN1639 配 GN1210 盖 	GN1210 配 GN1161 盖 				
GN 1638 T=1.0 MM	GN 1210 T=1.1 MM	GN 1967 T=1.2 MM	GN 1968 T=1.2 MM	GN 1639 T=1.2 MM	GN 1210 T=1.3 MM	GN 1210 T=1.3 MM	GN 1161 T=1.2 MM

组合管系列 COMBINED PIPE SERIES >>>

GN9855 配 GN9856 盖 	GN9857 配 GN9856 盖 	GN1757 配 GN1759 盖 	GN1299 配 GN1300 盖 				
GN 9855 T=1.8 MM	GN 9856 T=1.4 MM	GN 9857 T=1.8 MM	GN 9856 T=1.4 MM	GN 1757 T=2.0 MM	GN 1759 T=1.5 MM	GN 1299 T=1.2 MM	GN 1300 T=1.2 MM
GN2410 配 GN2411 盖 	GN0722 配 GN0723 盖 	GN1036 配 GN1035 盖 	GN0718 配 GN0719 盖 				
GN2410 T=1.0 MM	GN2411 T=1.0 MM	GN 0722 T=1.2 MM	GN 0723 T=1.2 MM	GN 1036 T=1.4 MM	GN 1035 T=1.4 MM	GN 0718 T=1.2 MM	GN 0719 T=1.2 MM
GN1259 配 GN1260 盖 	GN3672 配 GN3673 盖 	GN2210 配 GN1669 盖 	GN2097 配 GN2098 盖 				
GN 1259 T=2.4 MM	GN 1260 T=1.2 MM	GN 3672 T=1.0 MM	GN 3673 T=1.0 MM	GN 2210 T=1.4 MM	GN 1669 T=1.5 MM	GN 2097 T=1.1 MM	GN 2098 T=1.1 MM
GN1172 配 GN1173 盖 	GN1668 配 GN1669 盖 	GN2037 配 GN2038 盖 	GN2553 配 GN1669 盖 				
GN 1172 T=1.0 MM	GN 1173 T=1.2 MM	GN 1668 T=2.0 MM	GN 1669 T=1.5 MM	GN2037 T=1.0 MM	GN2038 T=1.0 MM	GN2553 T=1.2 MM	GN 1669 T=1.5 MM
GN2568 配 GN2566 盖 	GN1238 配 GN1173 盖 	GN2110 配 GN2111 盖 	GN1640 配 GN1173 盖 				
GN2568 T=1.9 MM	GN2566 T=1.2 MM	GN1238 T=1.0/1.2 MM	GN 1173 T=1.2 MM	GN2110 T=1.5/2.0 MM	GN2111 T=1.3 MM	GN 1640 T=1.2 MM	GN 1173 T=1.2 MM

组合管系列 COMBINED PIPE SERIES >>>

GN2567 配 GN2566 盖 	GN1241 配 GN3766 盖 	GN2109 配 2111 盖 	GN9871 配 9857 盖 				
GN2567 T=1.85 MM	GN2566 T=1.2 MM	GN 1241 T=1.4 MM	GN 3766 T=1.5 MM	GN2109 T=1.5 MM	GN2111 T=1.3 MM	GN 9871 T=1.8 MM	GN9857 T=1.7 MM
GN1795 配 GN1669 盖 	GN0720 配 GN0721 盖 	GN1249 配 GN1250 盖 	GN9877 配 9876 盖 				
GN 1795 T=1.8 MM	GN 1669 T=1.5 MM	GN 0720 T=1.2 MM	GN 0721 T=1.2 MM	GN 1249 T=1.8 MM	GN 1250 T=1.8 MM	GN 9877 T=1.0 MM	GN 9876 T=1.0 MM
GN9879 配 9876 盖 	GN1416 配 GN1417 盖 	GN9881 配 GN1417 盖 	GN1762 配 GN1763 盖 				
GN 9879 T=1.2 MM	GN 9876 T=1.0 MM	GN 1416 T=1.9 MM	GN 1417 T=1.3 MM	GN 9881 T=1.2 MM	GN 1417 T=1.3 MM	GN 1762 T=1.8 MM	GN 1763 T=1.8 MM
GN9883 配 9884 盖 	GN9885 配 9884 盖 						
GN 9883 T=1.8 MM	GN 9884 T=1.8 MM	GN 9885 T=2.0 MM	GN 9884 T=1.8 MM	GN2234 T=1.8 MM	GN2233 T=1.5 MM		
GN1782 配 GN1783 盖 	GN2653 配 GN2654 盖 						
GN 1782 T=1.5 MM	GN 1783 T=1.5 MM	GN 2653 T=1.5 MM	GN 2654 T=2.0 MM	GN 9821 T=1.8 MM	GN 9820 T=1.8 MM	GN 9901 T=2.0 MM	GN 9890 T=2.0 MM

组合管系列 COMBINED PIPE SERIES >>>

GN0922 配 GN0923 盖 	GN9987 配 GN9889 盖 	GN1153 配 GN1154 盖 	GN9905 配 GN2654 盖 				
GN 0922 T=1.5 MM	GN 0923 T=1.5 MM	GN 9887 T=1.4 MM	GN 9889 T=1.4 MM	GN 1153 T=1.9 MM	GN 1154 T=1.4 MM	GN 9905 T=2.0 MM	GN 2654 T=1.4 MM
GN1520 配 GN1519 盖 	GN2804 配 GN2805 盖 	GN1039 配 GN1040 盖 	GN1545 配 GN1546 盖 				
GN 1520 T=2.0 MM	GN 1519 T=1.4 MM	GN2804 T=1.2 MM	GN2805 T=1.4 MM	GN 1039 T=2.5 MM	GN 1040 T=2.5 MM	GN 1545 T=2.9 MM	GN 1546 T=1.2 MM
GN9887 配 GN9890 盖 	GN9891 配 GN9890 盖 	GN9893 配 GN9890 盖 	GN9897 配 GN9898 盖 				
GN 9887 T=2.0 MM	GN 9890 T=2.0 MM	GN 9891 T=2.0 MM	GN 9890 T=2.0 MM	GN 9893 T=2.0 MM	GN 9890 T=2.0 MM	GN 9897 T=1.5 MM	GN 9898 T=2.0 MM
GN9895 配 GN9898 盖 	GN1752 配 GN1753 盖 	GN2126 配 GN2127 盖 	GN2051 配 GN2052 盖 				
GN 9895 T=1.5 MM	GN 9898 T=2.0 MM	GN 1752 T=3.0 MM	GN 1753 T=1.5 MM	GN2126 T=3.0 MM	GN2127 T=2.0 MM	GN 2051 T=1.2 MM	GN 2052 T=1.2 MM
GN76A T=1.2 MM	GN76B T=1.2 MM	GN2169 T=1.0 MM	GN2168 T=1.0 MM	GN2225 T=2.0 MM	GN2226 T=1.2 MM	GN2692 T=5.0 MM	GN2693 T=2.0 MM

GN2664 T=1.3 MM	GN2665 T=1.3 MM	GN 1765 T=1.8 MM	GN 1766 T= 1.8 MM
GN1872 T= 2.0 MM	GN1870 T= 2.0 MM	GN 1096 T= 1.0 MM	GN 1097 T= 1.0 MM
GN 1098 T= 1.0 MM	GN 1099 T= 1.0 MM	GN 1100 T=1.0 MM	GN 1101 T= 1.0 MM
GN 1164 T= 1.0 MM	GN 1165 T= 1.5 MM	GN 1166 T=1.5 MM	GN 1167 T=1.5 MM
GN 1767 T= 1.8 MM	GN 1168 T= 1.5 MM	GN 1169 T=1.5 MM	GN 1162 T= 1.8 MM

GN 1163 T=2.0 MM	GN2362 T= 2.0 MM	GN 2389 T= 1.2 MM	GN 2388 T= 1.2 MM
GN2814 T=1.2 MM	GN2815 T=1.0 MM	GN2818 T=* MM	GN2819 T=1.2 MM
GN 2821 T= 1.9 MM	GN 2822 T= 1.4 MM	GN 2823 T=1.7 MM	GN 2836 T= 1.1 MM
GN 2846 T= 1.0 MM	GN 2847 T= 1.0 MM	GN 2848 T=1.1 MM	GN 2865 T=1.0 MM
GN2870 T=1.7 MM	GN2871 T=1.7 MM	GN2872 盖 T=1.8 MM	

GN 1624 T= 1.7 MM	GN 2090 T= 1.2 MM	GN 2321 T= 1.1 MM	GN 1020 T= 1.2 MM
GN 2435 T= 0.9 MM	GN 1019 T= 1.2/1.4 MM	GN 2619 T= 1.4 MM	GN 0958 T= 2.0 MM
GN 1712 T= 1.2 MM	GN 2185 T= 1.2 MM	GN 30X30TH T= 1.0MM	GN 0799 T= 0.8/1.5MM
GN 1420 T= 0.9 MM	GN 1501 T= 1.2 MM	GN 2813 T= 1.2 MM	GN 2290 T= 1.0 MM
GN 2785 T= 1.2 MM	GN 1947 T= 1.2 MM	GN 2016 T= 1.5 MM	GN 2120 T= 1.0 MM

GN 2015 T= 1.5 MM	GN 1805 T= 1.4 MM	GN 2147 T= 1.1 MM	GN 2515 T= 1.2 MM
GN 2516 T= 1.5 MM	GN 2416 T= 1.3 MM	GN 2417 T= 1.3 MM	GN 2570 T= 1.5 MM
GN 2571 T= 1.5 MM	GN 2777 T= 0.9 MM	GN 1093 T= 1.5 MM	GN 0823 T= 1.5 MM
GN 2442 T= 1.4 MM	GN 0856 T= 1.4 MM	GN 2734 T= 1.0 MM	GN 0917 T= 3.0 MM
GN 1754 T= 1.4 MM	GN 1837 T= 1.2 MM	GN 0658 T= 1.0 MM	GN 1957 T= 2.0 MM

GN 0846 T=1.2 MM	GN 1018 T=1.2 MM	GN 1022 T=1.2/1.4 MM	GN2119 T=1.4 MM
GN2451 T=2.0 MM	GN2160 T=1.4 MM	GN2159 T=1.4 MM	GN2320 T=1.5 MM
GN 1024 T=1.5 MM	GN 1787 T=1.4 MM	GN 1057 T=1.4 MM	GN2517 T=1.5 MM
GN 1608 T=2.0 MM	GN2453 T=2.0 MM	GN2222 T=1.7 MM	GN 1338 T=3.0 MM
GN 1445 T=2.4 MM	GN 1973 T= 2.0 MM	GN 1999 T= 1.5 MM	GN2184 T=1.2 MM

GN2779 T=1.0 MM	GN 1975 T=1.1 MM	GN2243 T=2.0 MM	GN 1180 T=1.2 MM
GN2704 T=1.2 MM	GN2167 T=1.5 MM	GN 0747 T=1.2 MM	GN 1734 T=1.4 MM
GN 1340 T=1.5 MM	GN 0839 T=2.0 MM	GN2391 T=2.0 MM	GN2380 T=1.5 MM
GN2265 T=1.0 MM	GN2264 T=1.0 MM	GN2778 T=1.0 MM	GN2375 T= 2.0 MM
GN2789 T=1.2 MM	GN 1946 T=1.2 MM	GN2434 T=0.9 MM	GN2303 T= 1.7 MM

GN 1349 T=1.2 MM	GN 1480 T=1.2 MM	GN2118 T=1.4 MM	GN 0821 T=1.5 MM
GN2707 T=1.5 MM	GN2733 T=1.2 MM	GN 1148 T=1.4 MM	GN2705 T=1.0 MM
GN2157 T=1.4 MM	GN2158 T=1.4 MM	GN2405 T=1.8 MM	GN2519 T=1.5 MM
GN2716-JC7001 T=3.0 MM	GN2706 T=1.8 MM	GN2198 T=2.5 MM	GN 1092 T=1.6 MM
GN2330 T=2.0 MM	GN 0919 T= 3.0 MM	GN 1964 T=1.2 MM	GN 1996 T=1.2 MM

GN2520 T=1.2 MM	GN2667 T=1.2 MM	GN2454 T=2.0 MM	GN2522 T=1.4 MM
GN 2521 T=1.5 MM	GN 2565 T=1.8 MM	GN 2261 T=2.0 MM	GN2787 T=1.8 MM
GN 1023 T=1.5 MM	GN 1620 T=1.8 MM	GN 1863 T=2.0 MM	GN2260 T=2.0 MM
GN2259 T=2.6 MM	GN 1735 T=2.9 MM	GN2329 T=1.4 MM	GN 0918 T= 3.0 MM
GN 1761 T=1.3 MM	GN 1377 T=1.8 MM	GN2412 T=1.5 MM	GN2594 T=1.4 MM

GN2523 T=1.4 MM	GN2708 T=1.8 MM	200X80 凹槽 T= 1.9 MM	GN2450 T=2.0 MM
GN2452 T=2.8 MM	GN0792 T=2.0 MM	GN0791 T= 2.0 MM	GN 0967 T= 2.0 MM
GN2379 T= 1.5 MM	GN1905 T= 1.9 MM	GN2336 T=1.9 MM	GN2327 T= 1.8 MM
GN2115 T= 2.0 MM	GN 1337 T= 3.0 MM	JJ-GN1515 T= 3.0 MM	GN2583 T= 3.0 MM
GN2524 T= 1.8 MM	GN2643 T= 2.3 MM	GN2961 T= 1.5 MM	GN2969 T= 2.2 MM

GN3045 T=1.2 MM	GN3073 T=1.0 MM	GN3080 T=1.8 MM	GN3115 T=1.8 MM
GN3377 T=1.8 MM	GN3420 T=2.0 MM	GN3426 T=0.8 MM	GN3217 T=1.5 MM
GN3218 T=1.5 MM	GN3219 T=1.5 MM	GN3220 T= MM	GN3221 T= MM
GN3298 T= 2.0 MM	GN3309 T= 1.8 MM	GN3352 T= 1.0 MM	GN 0867 T= 1.4 MM
GN 1424 T= 2.0 MM	GN 1266 T= 2.0 MM	GN 1186 T= 1.1 MM	GN 0974 T= 1.6 MM

GN2195 T=2.0 MM	GN1187 T=1.1 MM	GN1731 T=2.0 MM	GN1504 T=1.8 MM
GN1644 T=3.5 MM	GN1643 T=3.5 MM	GN2817 T=1.5 MM	GN2829 T=1.2 MM
GN2830 T=1.2 MM	GN2835 T=1.4 MM	GN2849 T=3.0 MM	GN2850 T=3.0 MM
GN2851 T=1.2 MM	GN9902 T=2.2 MM	GN9902 T=2.5 MM	

GN1175 T=1.9 MM	GN1176 T=1.9 MM	500301 T=1.2 MM	500201 T=1.2 MM
500101 T=1.2 MM	GN1226 T=1.8 MM	500401 T=1.0 MM	500501 T=1.0 MM

35X16 加强筋 T= 0.9/1.0/1.2/1.4/1.8/2.0/2.4/3.0/4.0/ MM	37.5x20 加强筋 T= 1.2 MM	37X18 加强筋 T= 1.0 MM	38X17 加强筋 T= 1.0 1.2 MM
GN1597 T=1.2 MM	40X17 加强筋 T= 1.5 MM	45.2X20 加强筋 T=1.7 MM	54X24 加强筋 T= 2.8 MM
GN1596 T=1.4 MM	GN1612 T= 1.1 MM	35X22 加强筋 T= 1.5 MM	34X20 加强筋 T=1.0 MM
40X20 加强筋 T=3.9 MM	GN2162 T= 1.0 MM	GN2164 T= 1.0 MM	40X17 加强筋 T= 1.5 MM
GN2229 T= 1.0 MM	GN0802 T= 1.0 MM	GN2128 T= 1.3 MM	GN2102 T= 1.7 MM

GN1567 T= 0.8 MM	GN2793 T=1.2 MM	GN2490 T= 1.5 MM	GN0803 T= 1.8 MM
GN10X10C 槽 T=0.8 MM	GN2199 T= 1.0 MM	GN1896 T=1.2 MM	10X18U 槽 T= 1.6 MM
GN0931 T=0.9 MM	GN1845 T= 1.0 MM	GN2614 T= 1.0 MM	GN2613 T=1.0 MM
12X12U 槽 T= 1.0 MM	GN0560 T= 1.2 MM	GN1956 T= 0.8 MM	10*15U 槽 T= 1.0 MM
15X15U 槽 T= 1.2 MM	GN2418 T= 0.8 MM	GN2209 T= 0.8 MM	GN2328 T= 0.8 MM

GN2105 T= 0.8 MM	GN1988 T= 0.8 MM	GN2649 T= 1.5 MM	SD-041 T= 1.3 MM
20X9X0.8U 槽 T=0.8 MM	GN0801 T= 1.0 MM	GN1255 T= 2.0 MM	GN1406 T= 1.0 MM
20X20U 槽 T= 1.4 / 2.0 MM	JJ-GN1817 T= 3.0 MM	GN0618 T= 2.3 MM	GN1217 T= 2.0 MM
GN1320 T= 0.8 MM	GN0605 T= 1.0 MM	GN2647 T= 3.0 MM	26X20U 槽 T= 3.0 MM
GN2703 T= 2.0 MM	GN1409 T= 0.9 MM	GN2487 T= 1.2 MM	GN1987 T= 0.8 MM

GN2489 T= 0.9 MM	30X30U 槽 T= 1.5 MM	GN2096 T= 2.5 MM	GN2474 T= 1.0 MM
GN1585 T= MM	32X38U 槽 T= 1.7 MM	GN2471 T= 1.0 MM	34X20U 槽 T= 1.9 MM
GN2742 T= 1.8 MM	GN1388 T= 2.3 MM	GN1875 T= 3.0 MM	37X19U 槽 T= 2.0 MM
GN0978 T= 2.3 MM	GN2504 T= 2.5 MM	38X20U 槽 T= 1.8 MM	GN2587 T= 2.5 MM
GN0886 T= 1.4 MM	GN1804 T= 2.5 MM	40X40U 槽 T= 3.0 MM	GN1547 T= 4.9 MM

加强筋系列 STIFFENER SERIES >>>

GN1598 T= 1.5 MM	GN2618 T= 1.8 MM	48X24U 槽 T= 1.8 MM	GN2615 T= 0.8 MM
GN2478 T= 1.0 MM	GN1989 T= 0.8 MM	GN2248 T= 2.7 MM	GN2539 T= 5.0 MM
53X30U 槽 T= 3.0 MM	GN0979 T= 2.9 MM	GN1662 T= 1.8 MM	GN1243 T= 3.0 MM
63X30U 槽 T= 3.0 MM	GN0980 T= 2.9 MM	GN2124 T= 6.4 MM	GN2545 T= 1.0 MM
GN1430 T= 10 MM	GN1934 T= 1.9 MM	GN1830 T= 1.2 MM	GN1461 T= 2.0 MM

加强筋系列 STIFFENER SERIES >>>

GN2123 T= 6.4 MM	GN1566 T= 2.0 MM	GN1746 T= 2.5 MM	GN1565 T= 2.0 MM
GN0447 T= 8.0 MM	GN2816 T= 3.0 MM	GN2831 T= 2.0 MM	GN2858 T= 3.0 MM
GN3060-37X15 加强筋 T= 1.9 MM			

地脚线系列 ANCHOR LINE SERIES



GN2752 T= 0.9 MM	GN2753 T= 0.9 MM	GN2759 T= 1.0 MM	GN 3008 T= 0.9 / 1.1MM

地脚线系列 ANCHOR LINE SERIES >>>

GN 2020 T= 1.2 MM	GN 2021 T= 1.2 MM	GN 2022 T= 1.0 MM	GN 2023 T= 0.9 MM
GN 2024 T= 1.2 MM	GN 2025 T= 0.8 MM	GN 2026 T= 0.8 MM	GN 2027 T= 1.2 MM
GN 2028 T= 0.9 MM	GN 2029 T= 0.8 MM	GN 2031 T= 0.7 MM	GN 2032 T= 0.9 MM
GN 2033 T= 0.8 MM	GN 2048 T= 1.0 MM	GN2089 T= 0.9 MM	GN 2505 T= 0.7 MM
GN2620 T= 2.0 MM	GN2652 T= 1.2 MM	GN2689 T= 2.0 MM	

龙骨系列 ANCHOR LINE SERIES >>>

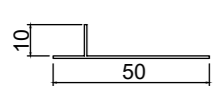
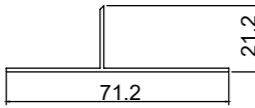
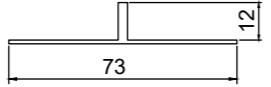
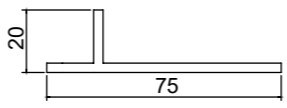
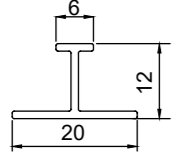
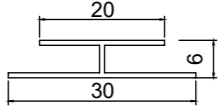
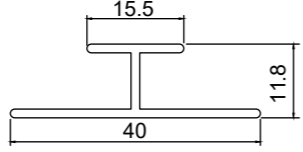
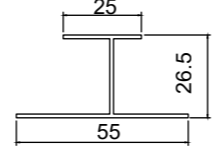
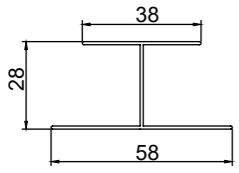
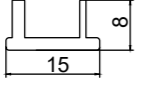
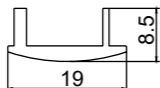
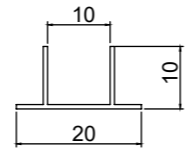
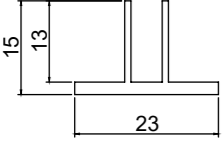
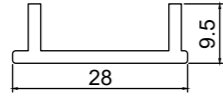
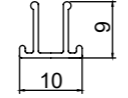
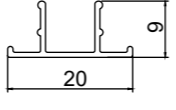
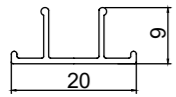
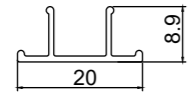
GN 20x10L T= 3.0 MM	GN2150 T= 1.2 MM	GN 0872 T= 1.0 MM	GN 1910 T= 0.9 MM
GN 0525 T= 1.2 MM	GN2175 T= 0.8 MM	GN 0313 T= 0.7 MM	GN 1898 T= 1.2 MM
GN 1899 T= 1.2 MM	GN 1707 T= 4.0 MM	GN 0516 T= 1.2 MM	GN 1831 T= 0.8 MM
GN 0386 T= 1.2 MM	GN 1348 T= 1.0 MM	GN2549 T= 3.0 MM	GN 1737 T= 1.0 MM
GN2444 T= 3.0 MM	GN 0288 T= 1.0 MM	GN2227 T= 1.2 MM	GN2295 T= 0.7 MM

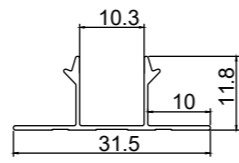
			
GN 1846 T= 0.8 MM	GN 1982 T= 1.2 MM	GN 0945 T= 1.2 MM	GN2443 T= 3.0 MM
			
GN 2043 T= 1.2 MM	GN2370 T= 0.8 MM	GN 1451 T= 1.4 MM	GN 1188 T= 1.2 MM
			
GN2702 T= 1.0 MM	GN 1375 T= 2.0 MM	GN 1374 T= 2.5 MM	GN2294 T= 0.7 MM
			
GN2200 T= 2.0 MM	GN 1422 T= 2.0 MM	GN 2067 T= 0.8 MM	GN 1134 T= 0.8 MM
			
GN 2066 T= 0.9 MM	GN 1438 T= 0.8 MM	GN 0891 T= 0.6 MM	GN 1315 T= 0.7 MM

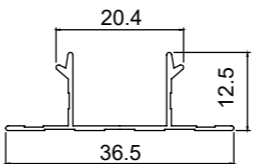
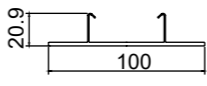
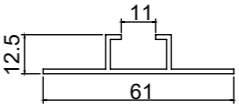
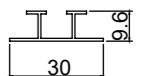
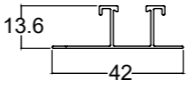
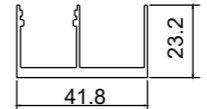
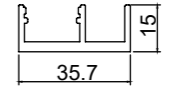
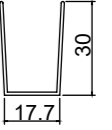
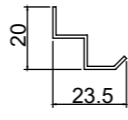
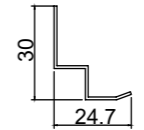
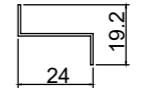
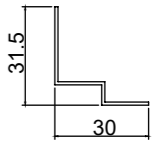
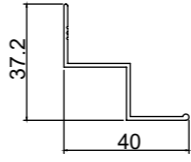
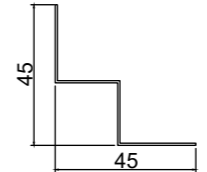
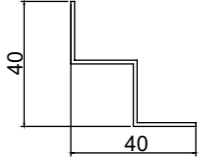
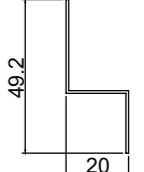
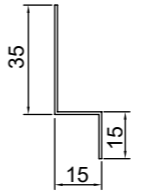
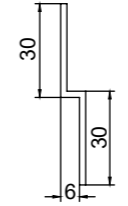
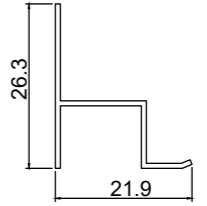
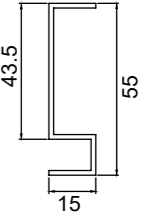
			
GN 1511 T= 0.8 MM	GN 1832 T= 0.8 MM	GN 1895 T= 1.5 MM	GN 1853 T= 0.9 MM
			
GN 1607 T= 0.9 MM	GN2001 T= 3.2 MM	GN1976 T= 1.8 MM	GN 0608 T= 1.0 MM
			
GN2491 T= 1.0 MM	GN2176 T= 0.9 MM	GN 1990 T= 0.8 MM	GN2095 T= 1.0 MM
			
GN 0576 T= 1.2 MM	GN 1473 T= 0.7 MM	GN 1713 T= 1.2 MM	GN2192 T= 0.9 MM
			
GN2247 T= 0.9 MM	GN2381 T= 2.0 MM	GN2228 T= 0.8 MM	GN 1940 T= 1.5 MM

龙骨系列 KEEL SERIES >>>

GN 0915 T= 2.0 MM	GN 0502 T= 1.0 MM	GN 1325 T= 2.0 MM	GN 1719 T= 1.2 MM
GN 0559 T= 1.0 MM	GN 0536 T= 8.8 MM	GN 1371 T= 0.9 MM	GN 1382 T= 1.2 MM
JJ-GN1216 T= 1.2 MM	GN 1936 T= 3.0 MM	GN2252 T= 4.0 MM	GN2401 T= 3.0 MM
GN 1449 T= 4.5 MM	GN 0599 T= 1.2 MM	GN 1392 T= 0.8 MM	GN 1341 T= 1.3 MM
GN 1342 T= 2.0 MM	GN 0543 T= 2.9 MM	T= MM	T= MM

盖板系列 COVER PLATE SERIES >>>

GN1047 T= 1.5 MM	15 封盖 T=0.7 MM	20 封盖 T=0.7 MM	20FG-2.0 T= 1.5 MM
25 封盖 T= 1.0 MM	30 封盖 T= 0.7 MM	30FG-2.0 T= 1.5 MM	35 封盖 T= 0.8 MM
40 封盖 T= 1.0 MM	40FG-2.0 T= 1.5 MM	44 封盖 T= 1.0 MM	50 封盖 T= 1.1 MM
配:3.0厚管 	配:2.0管 	配:3.0厚管 	
50 封盖 T= 1.1 MM	50FG-2.0 T= 1.5 MM	50FG-3.0 T= 1.5 MM	60FG-2.0 T= 1.5 MM
75 封盖 T= 1.2 MM	LC-GN0853 T= 1.1 MM	80FG-2.0 T= 1.5 MM	100 封盖 T= 1.2 MM

盖板系列 COVER PLATE SERIES >>>

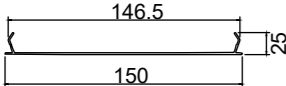
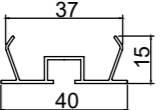
配:2.0管 			
150 封盖 T= 2.0 MM	GN2795 T= 1.0 MM	T= MM	T= MM

幕墙系列 CURTAIN WALL SERIES >>>

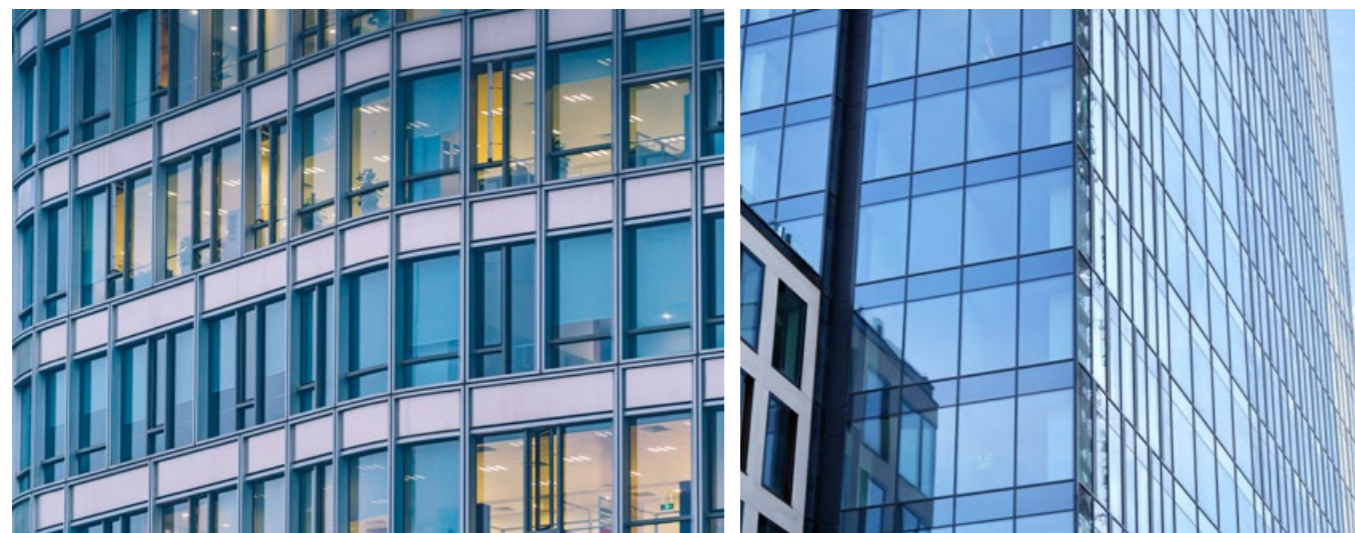

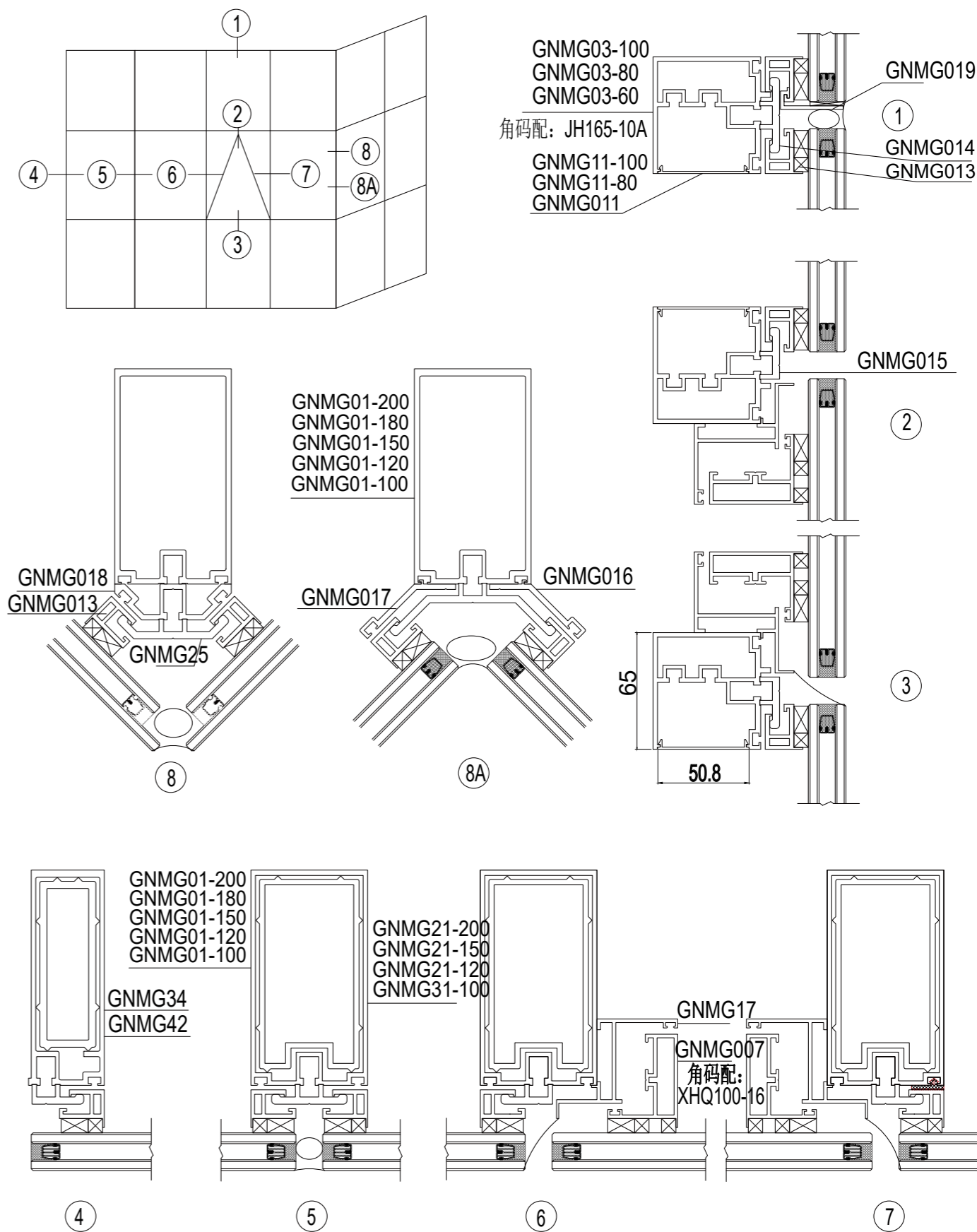

幕墙系列 CURTAIN WALL SERIES >>>

GNMG120、150、180、200 系列隐框中空玻璃幕墙结构图

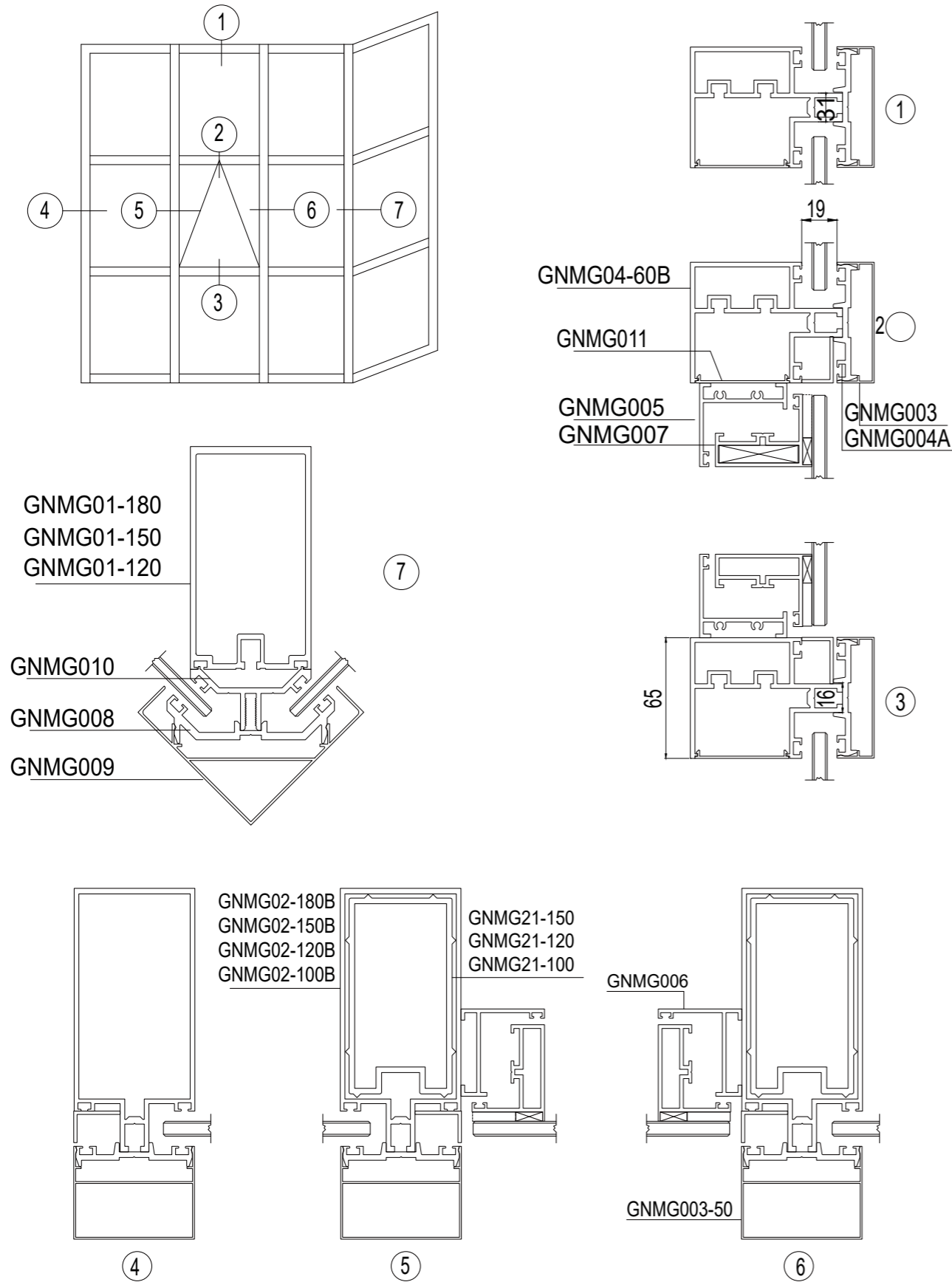

GNMG120、150、180、系列明框玻璃幕墙结构图

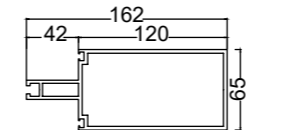
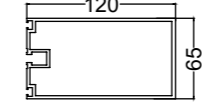
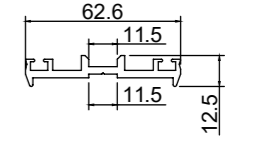
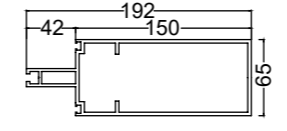
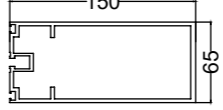
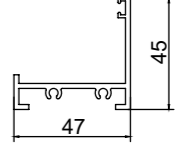
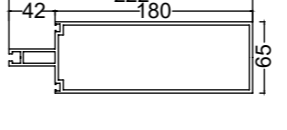
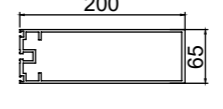
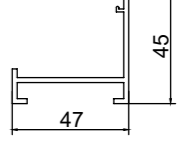
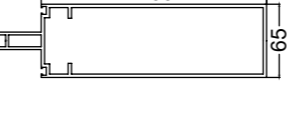
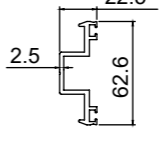
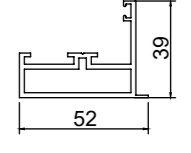
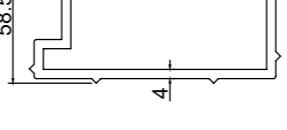
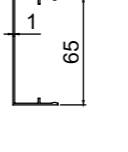
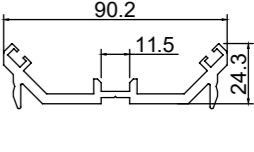
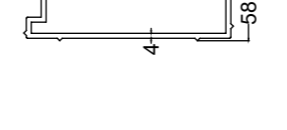

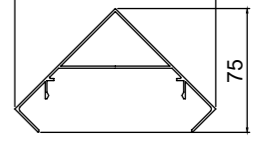
	GNMG120		GNMG01-120		GNMG04
	T=3.0MM		T=2.5MM		T=3.0MM
	4.01KG/M	连接柱配: GNMG120/150	3.087KG/M	连接柱配: GNMG003-50	0.818KG/M
	GNMG150		GNMG01-150		GNMG05
	T=3.0MM		T=3.0MM		T=2.0MM
	4.554KG/M	连接柱配: GNMG180/200	4.233KG/M		0.763KG/M
	GNMG180		GNMG01-200		GNMG06
	T=3.0MM		T=3.0MM		T=2.0MM
	5.05KG/M	连接柱配: GNMG180/200	4.98KG/M		0.685KG/M
	GNMG200		GNMG01		GNMG07
	T=3.0MM		T=2.5MM		T=2.0MM
	5.373KG/M		0.83KG/M	角码配: XHQ100-16	0.985KG/M
	GNMG 120/150		GNMG02		GNMG08
	T=4.0MM		T=1.0MM		T=4.0MM
	3.657KG/M		0.344KG/M	盖板配: GNMG009	1.660KG/M
	GNMG 180/200		GNMG03		GNMG09
	T=4.0MM		T=1.0MM		T=1.3MM
	4.97KG/M	盖板配: GNMG004	0.333KG/M		1.185KG/M

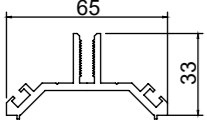
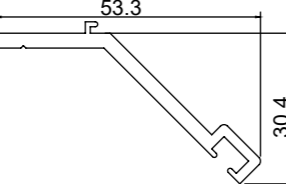
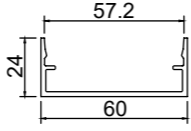
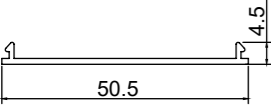
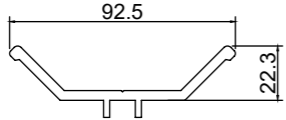
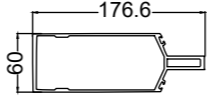
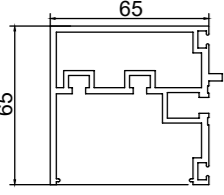
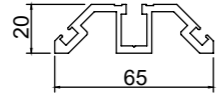
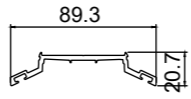
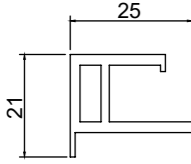
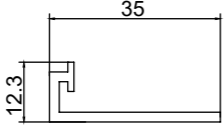
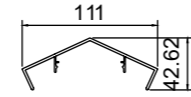
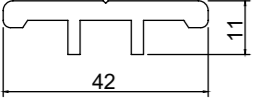
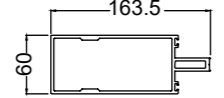
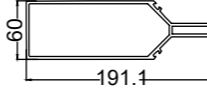
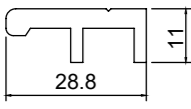
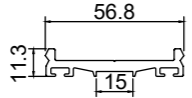
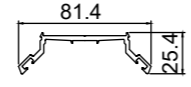
	GNMG10		GNMG16		GN1913
	T=3.0MM		T=3.0MM		T=2.0MM
	1.118KG/M		0.595KG/M		0.581KG/M
 <p>盖板配: GNMG03-60 GNMG04-60 GNMG05-60</p>	GNMG11		GNMG17		GN1914
	T=1.2MM		T=4.0MM		T=3.0MM
	0.205KG/M		1.280KG/M		3.58KG/M
 <p>盖板配: GNMG20</p>	GNMG12		GNMG18		GN1915
	T=2.5MM		T=3.0MM		T=*MM
	2.269KG/M		1.143KG/M		0.832KG/M
	GNMG13		GNMG19		GN1916
	T=2.3MM		T=2.0MM		T=2.0MM
	0.398KG/M		0.294KG/M		0.955KG/M
	GNMG14		GN1911		GN1917
	T=4.0MM		T=3.0MM		T=3.0MM
	0.639KG/M		3.95KG/M		3.98KG/M
	GNMG15		GN1912		GN1918
	T=4.0MM		T=*MM		T=*MM
	0.464KG/M		0.746KG/M		0.81KG/M

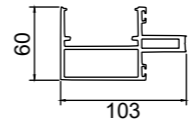
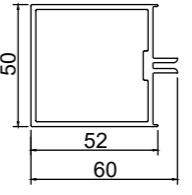
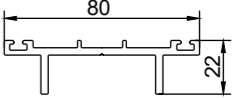
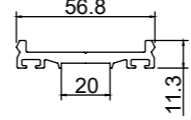
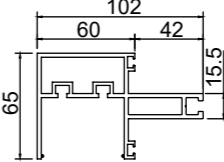
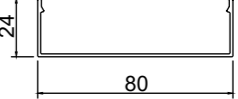
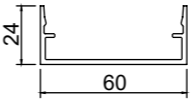
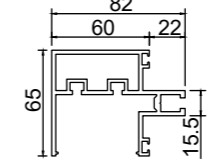
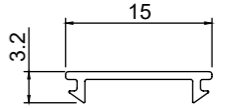
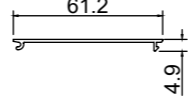
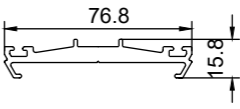
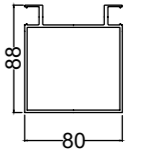
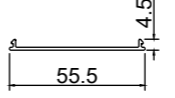
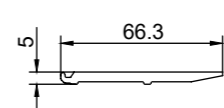
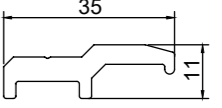
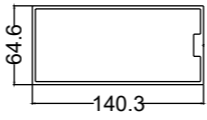
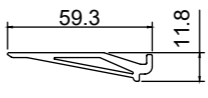
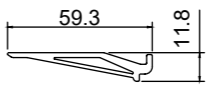
	GN1920		GNMQ-1003B		GN2939
	T=2.5MM		T=2.0MM		T=3.0MM
	2.71KG/M		1.206KG/M		0.997KG/M
	GN1921		GNMG40B		GN2940
	T=*MM		T=2.5MM		T=1.2MM
	0.756KG/M		2.553KG/M		0.423KG/M
	GN1922		GNMG04-60B		GN2941
	T=2.0MM		T=2.5MM		T=0.81MM
	0.581KG/M		2.27KG/M		0.044KG/M
	GN1923		GN2936		GN2942
	T=1.2MM		T=*MM		T=2.0MM
	0.225KG/M		1.203KG/M		1.945KG/M
 <p>配: GNMG12</p>	GNMG20		GN2937		GN2943
	T=1.2MM		T=*MM		T=*MM
	0.204KG/M		0.672KG/M		0.481KG/M
 <p>配 SH-1402</p>	GNMQ-1401B		GN2938		GN2938
	T=2.5MM		T=*MM		T=*MM
	2.974KG/M		0.616KG/M		MM
					KG/M

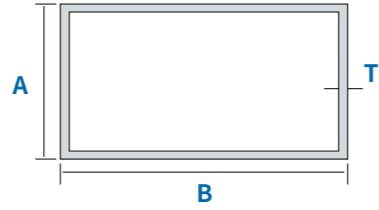

规格 (mm) 宽 * 高	壁厚 (mm)	规格 (mm) 宽 * 高	壁厚 (mm)	规格 (mm) 宽 * 高	壁厚 (mm)	
10*10	1.00	25*15	1.00	30*30	1.50	
12*12	1.80		1.20		1.80	
15*7	0.50		1.50		2.00	
15*10	1.00	25*20	0.90	32*32	2.50	
	1.20		1.20		3.00	
	2.00		1.20		1.00	
15*15	1.00	25*25	1.50	35*15	1.20	
	1.20		0.50		1.50	
	1.50		0.80		0.90	
	2.00		1.00	2.00		
16*16	1.20		30*8	1.20	35*25	2.00
	1.00			1.50		3.00
	1.20			1.80		35.2*22.3
19*19	1.00	30*10	2.00	38*20	1.00	
	1.20		2.50		38*25	0.50
	2.00		3.00			0.60
20*10	0.80	30*15	1.00	38*38		0.80
	1.00		1.20		1.00	
	1.20		1.50		1.20	
	1.50	1.80	1.50			
	2.00	2.00	2.00			
20*15	0.80	30*20	0.80	40*10	2.50	
	1.00		0.80		3.00	
	1.20		0.90		0.80	
	1.60	1.00	1.00			
2.00	1.20	1.20	1.00			
20*16	1.20	30*25	1.50	40*15	1.20	
20*17	2.00		1.80		1.50	
20*20	0.60		3.00		2.00	0.80
	0.80		0.70		2.50	1.00
	1.00		0.90		3.00	1.20
	1.20	1.00	1.60	1.50		
	1.50	1.20	2.00	2.00		
	1.80	1.50	2.00	0.60		
2.00	1.80	30*30	0.60	40*20	0.80	
2.50	0.60		1.00		1.00	
3.00	0.80		1.20		1.20	
22*10	1.00		1.50		1.50	
22*22	1.20		1.80		1.80	
25*10	1.00					
	1.20					
	1.50					

规格 (mm) 宽 * 高	壁厚 (mm)	规格 (mm) 宽 * 高	壁厚 (mm)	规格 (mm) 宽 * 高	壁厚 (mm)		
40*20	2.00	50*15	1.20	50*50	2.00		
	2.50		1.50		2.50		
	3.00	50*20	0.70		3.00		
40*25	0.70		0.80		4.00		
	0.90		0.90		5.00		
	1.20		1.00		6.00		
	1.40		1.20	54*27 方管	1.50		
	1.60	1.50	55*30	2.00			
2.00	1.80	60*10	1.00	60*15	1.00		
40*27	2.00		1.20		1.80		
40*28	2.00	50*25	1.00	60*20	1.80		
40*30	0.60		0.60		2.00	60*25	0.70
	0.80		0.80	2.50	0.80		
	1.00		0.90	3.00	0.80		
	1.20		1.00	3.00	1.00		
	1.50		1.20	3.00	1.20		
	1.80		1.50	3.00	1.50		
	2.00		1.80	50*30	1.80	60*30	1.80
	2.50		2.00		2.00		2.00
	3.00		2.50		2.50		2.50
	40*40	0.60	3.00		3.00		3.00
0.80		50*35	0.70		60*35		0.80
1.00			0.80	0.90			
1.20			0.90	1.00			
1.50			1.00	1.20			
1.80	1.20		1.50				
2.00	1.50	50*40	1.80	60*38	0.70		
2.50	1.80		2.00		0.80		
3.00	2.00		2.50		0.90		
45*20	2.00		3.00		3.00	1.00	
	45*25		0.80		50*45	1.20	1.40
		0.90	1.50	1.50			
1.00		2.00	1.80				
1.20	48*29	2.00	50*50	2.00			
1.50		0.60		0.60			
2.00		0.80		0.80			
45*45	1.50	50*5	0.90	60*40	1.20		
1.80	1.00		1.00		1.50		
2.00	1.20		1.20		1.80		
3.00	1.50		1.50		2.00		
48*29	2.00	50*7	1.00	60*50	1.00		
50*5	0.90		1.20		1.20		
50*7	1.00		2.50		3.00		
50*10	1.00	60*10	1.00	60*50	1.00		
	1.20		1.00		1.20		
	2.50		1.20		1.50		
	3.00		1.50		1.80		

规格 (mm) 宽 * 高	壁厚 (mm)	规格 (mm) 宽 * 高	壁厚 (mm)	规格 (mm) 宽 * 高	壁厚 (mm)
60*50	1.50	70*50	3.00	76*76	1.50
	2.00		6.50		1.90
	3.00	70*60 方管	3.0		2.00
60*60	0.80	70*70	1.50		3.00
	1.00		1.80		6.50
	1.20		3.00	1.00	
	1.50		6.00	1.20	
	1.80	74*24	0.60	2.00	
	2.00	75*25	1.00	80*10	1.20
	2.50		1.50	80*13	1.20
	2.80		1.80	80*15	1.50
4.00	75*30	1.00	80*20	0.80	
70*10		1.00		1.00	1.00
70*12		1.00		1.20	1.20
70*15		1.00		1.50	1.50
70*20		0.80		2.50	2.00
	1.00	75*35	2.50	2.50	
	1.50		0.60	0.80	
2.00	1.00		1.00		
70*25	2.00	1.20	1.20	1.00	
70*30	0.70	1.50	1.50	1.20	
	0.80	1.80	1.80	1.50	
	1.00	75*45	1.80	1.50	
	1.20	75*50	0.90	2.00	
	1.50		1.00	2.00	
	1.80		1.50	3.00	
	2.00	75*70	1.50	0.80	
	2.50	75*75	1.80	0.90	
	3.00	76*23 圆角	5.50	1.00	
	70*30 (0875)	2.00	76*20	1.20	1.20
70*40	0.80	76*25	0.80	1.80	
	1.00		0.80	2.00	
	1.20		1.00	2.50	
	1.50		1.20	3.00	
	1.80		1.30	0.70	
	2.00	1.50	0.80		
	2.50	1.80	0.90		
	3.00	2.00	1.00		
70*50	0.80	76*38	6.50	1.20	
	1.00	76*44	0.60	1.50	
	1.20		0.90	1.80	
	1.50		1.00	2.00	
	1.80		1.20	2.50	
	2.00		1.40	3.00	
	2.50		1.60	4.00	
	80*44		1.20	80*50	0.70
0.80			0.80		

规格 (mm) 宽 * 高	壁厚 (mm)	规格 (mm) 宽 * 高	壁厚 (mm)	规格 (mm) 宽 * 高	壁厚 (mm)
80*50	0.90	90*50	0.80	100*40	0.80
	1.00		1.00		0.90
	1.20		1.20		1.00
	1.50		1.50		1.20
	1.80		1.80		1.50
	2.00		2.00		1.80
	2.50	90*90	1.60		2.00
	3.00		2.00		
	4.00	91.3*22.2	1.00		2.50
	80*60	1.00	95*20		1.50
1.20		100*10	1.00	3.50	
1.50			1.50	4.00	
1.80			2.00		
2.00		100*15	0.80	0.80	
2.50			0.90	0.90	
3.00			1.00	1.00	
3.00		80*80	1.20	1.20	
3.50	1.50		1.50		
4.00	1.80		1.80		
5.00	2.00		2.00		
85*18	1.20		2.50	2.50	
	1.50		3.00	3.00	
	1.80		4.00	4.00	
	2.00		5.00	5.00	
	2.50	86*26	1.00		
	3.00	90*20	0.80	0.80	
3.50	0.90		0.90		
4.00	1.00		1.00		
5.00	1.20		1.20		
86*26	1.00		1.60	1.60	
	1.20		2.00	2.00	
	1.50	2.50	2.50		
	2.00	3.00	3.00		
	2.50	100*20	0.80	0.80	
	3.00		0.90	0.90	
4.00	1.00		1.00		
5.00	1.20		1.20		
80*30	0.80		1.50	1.50	
	0.90		1.80	1.80	
	1.00	2.00	2.00		
	1.20	2.50	2.50		
	1.50	3.00	3.00		
	2.00	90*30	0.80	0.80	
2.50	0.90		0.90		
3.00	1.00		1.00		
4.00	1.20		1.20		
5.00	1.50		1.50		
80*40	1.80		2.00	2.00	
80*40	0.70	100*25	0.80	0.80	
	0.80		0.90	0.90	
	0.90		1.00	1.00	
	1.00		1.20	1.20	
	1.20		1.50	1.50	
	1.50		1.80	1.80	
80*44	1.20	100*30	2.00	2.00	
	1.50		3.00	3.00	
	1.80		3.00	3.00	
	2.00		3.00	3.00	
	2.50		3.00	3.00	
	3.00		3.00	3.00	
80*50	0.70	100*30	3.00	3.00	
	0.80		3.00	3.00	
	100*40		0.80	0.80	0.80
			0.90	0.90	0.90
			1.00	1.00	1.00
			1.20	1.20	1.20
1.50		1.50	1.50		
1.80		1.80	1.80		
80*44	1.20	100*30	2.00	2.00	
	1.50		2.00	2.00	
	1.80		2.00	2.00	
	2.00		2.00	2.00	
	2.50		2.00	2.00	
	3.00		2.00	2.00	
80*50	0.70	100*30	3.00	3.00	
	0.80		3.00	3.00	
	100*40		0.80	0.80	0.80
			0.90	0.90	0.90
			1.00	1.00	1.00
			1.20	1.20	1.20
1.50		1.50	1.50		
1.80		1.80	1.80		
100*44	1.20	100*30	2.00	2.00	
	1.50		2.00	2.00	
	2.00		2.00	2.00	
	2.50		2.00	2.00	
	3.00		2.00	2.00	
	3.10		2.00	2.00	
100*50	0.70	100*30	3.00	3.00	
	0.80		3.00	3.00	
	0.90		3.00	3.00	
	1.00		3.00	3.00	
	1.20		3.00	3.00	
	1.50		3.00	3.00	
100*50	1.80	100*30	3.00	3.00	
	2.00		3.00	3.00	
	2.50		3.00	3.00	
	3.00		3.00	3.00	
	3.10		3.00	3.00	
	3.50		3.00	3.00	
100*44	0.80	100*30	3.00	3.00	
	0.90		3.00	3.00	
	1.00		3.00	3.00	
	1.20		3.00	3.00	
	1.50		3.00	3.00	
	2.00		3.00	3.00	
100*44	1.20	100*30	3.00	3.00	
	1.50		3.00	3.00	
	2.00		3.00	3.00	
	2.50		3.00	3.00	
	3.00		3.00	3.00	
	3.10		3.00	3.00	
100*50	0.70	100*30	3.00	3.00	
	0.80		3.00	3.00	
	0.90		3.00	3.00	
	1.00		3.00	3.00	
	1.20		3.00	3.00	
	1.50		3.00	3.00	
100*50	1.80	100*30	3.00	3.00	
	2.00		3.00	3.00	
	2.50		3.00	3.00	
	3.00		3.00	3.00	
	3.10		3.00	3.00	
	3.50		3.00	3.00	
100*44	0.80	100*30	3.00	3.00	
	0.90		3.00	3.00	
	1.00		3.00	3.00	
	1.20		3.00	3.00	
	1.50		3.00	3.00	
	2.00		3.00	3.00	
100*44	1.20	100*30	3.00	3.00	
	1.50		3.00	3.00	
	2.00		3.00	3.00	
	2.50		3.00	3.00	
	3.00		3.00	3.00	
	3.10		3.00	3.00	
100*50	0.70	100*30	3.00	3.00	
	0.80		3.00	3.00	
	0.90		3.00	3.00	
	1.00		3.00	3.00	
	1.20		3.00	3.00	
	1.50		3.00	3.00	
100*50	1.80	100*30	3.00	3.00	
	2.00		3.00	3.00	
	2.50		3.00	3.00	
	3.00		3.00	3.00	
	3.10		3.00	3.00	
	3.50		3.00	3.00	
100*44	0.80	100*30	3.00	3.00	
	0.90		3.00	3.00	
	1.00		3.00	3.00	
	1.20		3.00	3.00	
	1.50		3.00	3.00	
	2.00		3.00	3.00	
100*44	1.20	100*30	3.00	3.00	
	1.50		3.00	3.00	
	2.00		3.00	3.00	
	2.50		3.00	3.00	
	3.00		3.00	3.00	
	3.10		3.00	3.00	
100*50	0.70	100*30	3.00	3.00	
	0.80		3.00	3.00	
	0.90		3.00	3.00	
	1.00		3.00	3.00	
	1.20		3.00	3.00	
	1.50		3.00	3.00	
100*50	1.80	100*30	3.00	3.00	
	2.00		3.00	3.00	
	2.50		3.00	3.00	
	3.00		3.00	3.00	
	3.10		3.00	3.00	
	3.50		3.00	3.00	
100*44	0.80	100*30	3.00	3.00	
	0.90		3.00	3.00	
	1.00		3.00	3.00	
	1.20		3.00	3.00	
	1.50		3.00	3.00	
	2.00		3.00	3.00	
100*44	1.20	100*30	3.00	3.00	
	1.50		3.00	3.00	
	2.00		3.00	3.00	
	2.50		3.00	3.00	
	3.00		3.00	3.00	
	3.10		3.00	3.00	
100*50	0.70	100*30	3.00	3.00	
	0.80		3.00	3.00	
	0.90		3.00	3.00	
	1.00		3.00	3.00	
	1.20		3.00	3.00	
	1.50		3.00	3.00	
100*50	1.80	100*30	3.00	3.00	
	2.00		3.00	3.00	
	2.50		3.00	3.00	
	3.00		3.00	3.00	
	3.10		3.00	3.00	
	3.50		3.00	3.00	
100*44	0.80	100*30	3.00	3.00	
	0.90		3.00	3.00	
	1.00		3.00	3.00	
	1.20		3.00	3.00	
	1.50		3.00	3.00	
	2.00		3.00	3.00	
100*44	1.20	100*30	3.00	3.00	
	1.50		3.00	3.00	
	2.00		3.00	3.00	
	2.50		3.00	3.00	
	3.00		3.00	3.00	
	3.10		3.00	3.00	
100*50	0.70	100*30	3.00	3.00	
	0.80		3.00	3.00	
	0.90		3.00	3.00	
	1.00		3.00	3.00	
	1.20		3.00	3.00	
	1.50		3.00	3.00	
100*50	1.80	100*30	3.00	3.00	
	2.00		3.00	3.00	
	2.50		3.00	3.00	
	3.00		3.00	3.00	
	3.10		3.00	3.00	
	3.50		3.00	3.00	
100*44	0.80	100*30	3.00	3.00	
	0.90		3.00	3.00	
	1.00		3.00	3.00	
	1.20		3.00	3.00	
	1.50		3.00	3.00	
	2.00		3.00	3.00	
100*44	1.20	100*30	3.00	3.00	
	1.50		3.00	3.00	
	2.00		3.00	3.00	
	2.50		3.00	3.00	
	3.00		3.00	3.00	
	3.10		3.00	3.00	
100*50	0.70				

规格 (mm) 宽 * 高	壁厚 (mm)	规格 (mm) 宽 * 高	壁厚 (mm)	规格 (mm) 宽 * 高	壁厚 (mm)		
100*75	2.00	120*25	3.00				
100*80	1.00	120*30	0.90	120*100	1.50		
	1.20		1.00		1.80		
	1.50		1.20		2.00		
	1.80		1.50		2.50		
	2.00		1.80	3.00			
	2.50		2.00	4.00			
	2.80		2.50	1.50			
	3.00		3.00	2.00			
100*90	2.00	120*40	0.90	120*120	2.50		
100*100	1.10		1.00		3.00		
	1.20		1.20		4.00		
	1.50		1.50		125*50	3.00	
	1.80		1.60	125*65	2.00		
	2.00		1.80	130*30	1.50		
	2.30		2.00		1.80		
	2.50		2.50	130*40	2.00		
	3.00		3.00		1.40		
	3.80		4.00	1.80			
	4.00		0.90	130*50	1.80		
5.00	1.00		130*60	1.50			
6.00	1.20	130*65	2.00				
110*30	1.10	120*50	1.50	130*100	3.00		
110*40	1.50		1.80		1.50		
110*50	1.50		2.00		2.00		
110*60	1.80		2.50	130*130	2.50		
110*65	2.50		3.00		3.00		
116*76 (GN0941)	1.90		1.00		2.00		
110*110	2.00	120*60	1.20	136*50	140*20	1.00	
	2.80		1.50		140*25	1.30	
120*10	1.20		1.80		140*30	1.50	
120*15	1.20		2.00		140*50	1.80	
120*20	0.90		2.50		2.50	140*60	1.50
	1.00		3.00		3.00	140*65	2.00
	1.20		4.00	140*70	2.00		
	1.50		120*65	2.00	140*80	1.50	
	1.80		120*70	3.00	140*100	1.80	
	2.00		120*80	1.20	140*120	2.00	
2.50	1.30			140*140	2.00		
120*25	0.90			1.50	2.00	2.50	
	1.00	1.80		2.50	3.00		
	1.20	2.00		3.00	4.00		
	1.50	2.50		150*10	1.20		
	1.80	3.00	150X15	1.20			
	2.00	4.00					
2.50	120*100	1.20					

规格 (mm) 宽 * 高	壁厚 (mm)	规格 (mm) 宽 * 高	壁厚 (mm)	规格 (mm) 宽 * 高	壁厚 (mm)	
150*20	0.9	150*60	1.30	150*150	3.50	
	1.00		1.50		4.00	
	1.00		1.80		5.00	
	1.20		2.00		6.00	
	1.50		2.50		160*20	1.50
	1.80		3.00		160*25	2.00
	2.00		4.00	160*30	2.00	
	2.50		2.00		2.50	
	3.00		2.80	160*40	1.50	
	150*25		0.90	150*70	1.50	160*50
1.00		1.80	160*60		1.50	
1.20		2.00	160*60		2.00	
1.50		3.00	160*70		2.00	
1.80		150*75	1.50	160*80	1.30	
2.00			1.80		1.50	
2.50			2.00		2.00	
3.00			2.50		2.50	
150*30			0.90		3.00	3.00
			1.00		1.30	160*100
	1.20	1.50	160*100	2.00		
	1.50	1.80	160X160	2.00		
1.80	2.00	2.50				
2.00	2.50	3.00	3.00			
2.50	3.00	150*80	4.00	180*20	2.00	
3.00	4.00		1.60			
150*40	0.90		1.30		1.50	180*25
	1.00		1.50	1.60	2.00	
	1.20		1.80	1.80	180*30	1.50
	1.50		2.00	2.00		1.80
	1.80	2.50	2.30	2.00		
	2.00	2.50	2.50	2.50		
2.50	3.00	2.80	180*40	1.50		
3.00	3.00	3.00		1.80		
150*50	1.00	3.50		2.00	180*50	1.50
	1.10	4.00		2.50		1.80
	1.20	4.50		3.00		2.00
	1.50	5.00		4.00		2.50
	1.80	2.00	150*120	2.00		
	2.00	2.50	2.50	2.50		
	2.40	3.00	3.00	3.80		
	2.50	4.00	4.00	4.00		
	2.90	1.80	150*150	1.50	180*60	1.50
	3.00	2.00		2.00		2.00
3.00	2.30	2.30		2.80		
4.00	3.00	3.00		3.00		
150*60	1.00			180*75	2.00	
	1.20					

规格 (mm) 宽 * 高	壁厚 (mm)	规格 (mm) 宽 * 高	壁厚 (mm)	规格 (mm) 宽 * 高	壁厚 (mm)	
180*75	2.50	200*50	2.00	200*150	1.60	
	3.00		2.30		2.00	
180*80	2.00		2.50		2.30	
	3.00		2.80		2.50	
	4.80		3.00		2.80	
180X100	1.80		4.00		3.00	3.00
	2.00	5.00	4.00			
	2.50	1.40 带筋	5.00			
	3.00	1.60	200*180	2.50		
180*120	2.50	200*60	1.80	200*200	2.00	
	2.50		2.00		2.50	
180*180	2.50		2.30		3.00	
	3.00		2.50		3.50	
190*50	2.00	3.00	4.00			
198*44	2.50	200*65	2.80		5.00	
200X10	1.80	200*70	2.00	210*210	6.00	
	2.00		2.50		3.00	
	2.50		3.00			
200X15	2.00	200*75	1.80		225*50	2.00
200X20	1.50		2.50		240*30	1.5 加筋
	1.80		3.00		250*20	2.20
	2.00	200*80	1.60	250*25	2.20	
	2.50		1.80	250*30	1.6 带筋	
3.00	2.00		2.00			
200X25	1.50		2.30		2.20	
	1.80	2.50	3.00			
	2.00	2.80	4.00			
	2.50	3.00	250*40	1.6 带筋		
3.00	4.00	2.20				
200X30	1.50	200*90		2.00	2.50	
	1.80			2.50	3.00	
	2.00		3.00	4.00		
	2.30	200*100	1.50	250*50	1.6 带筋	
	2.50		1.80		1.8 带筋	
	3.00		2.00		2.00	
4.00	2.20		2.50			
200X40	1.3 带筋		2.50		3.00	
	1.50		2.80		3.50	
	1.80	3.00	4.00			
	2.00	3.50	2.20			
	2.30	4.00	2.50			
	2.50	5.00	3.00			
	3.00	6.00	4.00			
	4.00	200*120	2.00	250*80	2.00	
200*50	1.3 带筋		2.50		2.50	
	1.50		2.80		3.00	
	1.80	3.00	4.00			

规格 (mm) 宽 * 高	壁厚 (mm)	规格 (mm) 宽 * 高	壁厚 (mm)
250X100	1.60	300*75	3.00
	2.00	300*80	2.0 带筋
	2.20		2.50
	2.50		3.00
	2.80	300*90	4.00
	3.00		3.00
	3.50	300X100	2.30
	4.00		2.50
5.00	2.80		
250*120	2.00		3.00
	2.50		3.50
	2.80	4.00	
	3.00	5.00	
250*150	4.00	300*120	2.70
	2.00		3.00
	2.50		3.50
	2.80		4.00
	3.00	300*150	2.60
3.30	3.00		
4.00	3.50		
3.00	4.00		
3.50	5.00		
250*200	4.00	300*180	3.50
	4.00	300*200	3.50
250*250	5.00		4.00
300X20 带筋	2.20	300*300	4.50
300X25	1.8 带筋	350*50	3.00
	2.50		3.50
300*30	3.00	350*60	4.00
	2.0 带筋	350*80	3.50
	2.50	350*100	3.50
3.00	4.00		
300*40	2.50	400X50	3.00
	3.00	4.00	
300*50	1.8 带筋	400X100	3.50
	2.0 带筋		4.00
	2.20		12.50
	2.50	400X130	4.00
	2.80	400X200	4.00
	3.00		5.50
3.50	400X400	4.50	
300*60	4.00	500X70	5.00
	1.8 带筋	500X100	6.00
	2.00	500X200	5.00
	2.50	600X200	5.00
300*70	3.00	700X100	4.00
	2.50		
	3.00		

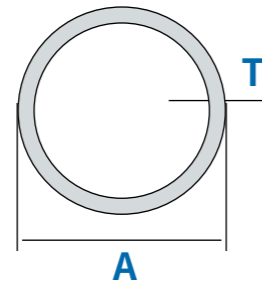

型材编号	壁厚 (mm)
6YG	2.00
7.5YG	1.00
8.9YG	4.50
9.7YG	1.00
12.5YG	1.20
15YG	1.00
	1.20
	2.00
15.5YG	0.50
	1.00
16YG	1.00
	1.20
19YG	1.00
	1.20
	1.50
20YG	1.00
	1.20
	1.50
	2.00
	3.00
21YG	1.00
	1.20
	1.50
	2.00
22YG	1.20
23.7YG	1.20

型材编号	壁厚 (mm)
24.9YG	1.50
25YG	0.80
	1.00
	1.20
	1.50
	1.80
	2.00
	2.50
28YG	3.00
	1.20
	1.40
29.4YG	1.40
29.8YG	2.00
30YG	0.80
	1.00
	1.20
	1.50
	1.80
	2.00
	3.00
	4.00
31YG	5.00
	1.50
36YG	1.80
38YG	1.00
	1.20

型材编号	壁厚 (mm)
40YG	0.80
	1.00
	1.20
	1.50
	2.00
	3.00
	4.00
46YG	5.00
48YG	1.50
50YG	1.00
	0.80
	1.00
	1.20
	1.50
	2.00
	2.50
	2.80
	3.00
	3.70
50.8YG	4.00
	1.80
59YG	3.00
60YG	1.00
	1.20
	1.50
	2.00
	3.00
70YG	4.00
	1.00
	1.50
	2.00
75YG(GN0796)	3.00
	4.00
	1.00
76YG	1.50
80YG	2.00
	0.90
	1.00
	1.20
	1.50
	2.00
	2.50
	3.00
4.00	

型材编号	壁厚 (mm)
83YG	6.80
90YG	2.00
100YG	1.20
	1.50
	1.80
	2.00
	3.00
110YG	4.00
	2.00
	2.00
120YG	3.00
	4.00
150YG	1.80
	2.00
	2.50
	3.00
	4.00
160YG	5.00
	2.00
180YG	3.00
	2.00
	2.50
191YG	8.50
200YG	2.50
	3.00
	4.00
	5.00
220YG	3.00
	3.50
230YG	4.00
	5.00
240YG	5.00
250YG	5.00
260YG	5.00
270YG	5.00
280YG	5.00
290YG	5.00
300YG	5.00
310YG	5.00
320YG	10.00
320YG	20.00
320YG	40.00
320YG	50.00
320YG	85.00

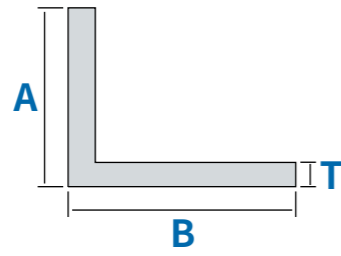

图号	模具编号	厚度
SL-GN0677	6.5*6.5	2.00
	8*8 角	2.00
GN1683	10.5 角	1.00
		2.00
	10x5 角 带圆角	2.00
	10*6 角铝	0.60
	10*7 角铝	0.80
	10*10	1.00
LC-GN0538		1.50
LC-GN0538		2.50
		3.00
GN2476	10*10 角	1.30
GN0920	10*15	1.00
GN1658	10*20 角	1.00
GN1274	11*6 角铝	*
	11x7 角	*
GN1360	11.9*12.8 角铝	1.20
GN1437	12*10 角铝	1.00
GY-GN0352	12*12	0.90
	12*12	1.20
		1.30
		1.50
		1.80
		2.00
	13*13 角	1.20
GN1273	14*35.5 角	*
	15*15 角	1.00

图号	模具编号	厚度
GN2208	15*17 角	0.80
	15*25 角	1.10
		1.20
		1.50
		1.80
	15*27 角	2.00
LC-GN0552	16*10 角	3.00
	18*12 角	1.30
		1.80
		2.00
	19*19	1.80
	19.5*19.5 角	1.00
GN1272	19*35.5 角	*
	20*5 带圆角	2.00
LC-GN0245	20*10 角	0.50
		0.80
GN1658		1.00
GN1215		1.00
	20*15 角	2.00
	20*20 角	1.00
		1.60
		2.00
		2.50
	20*22 角	3.00
	20*26	4.00
	25*6	1.80
	25*28 角	2.90

图号	模具编号	厚度
	25*15	1.20
		1.30
		1.50
		1.80
	25*20	1.50
	25*25	1.00
		1.80
		2.00
	25*25 角铝 (圆角)	3.00
CL-GN0638		2.00
	27*17	2.00
	28*19	3.20
	28*25	3.00
CL-GN0246	30*10 角	0.50
	30X15 角	3.0
GN1183	30*20	0.80
		1.00
		1.50
		2.00
		2.50
		3.00
	30*25	3.00
GN1183	30*30 角	0.80
	30*30	1.00
		1.50
		2.00
		2.80
GN0515	30*33	1.00
SL-GN0550	32*32	3.00
	38X38	3.00
	39.5*26	3.00
XR-GN0395	39.5 花角	8.90
	40*20	1.80
		3.00
SL-GN0134	40*30	1.20
		1.50
		2.00

图号	模具编号	厚度
	40*40	2.00
		3.00
		4.00
		6.00
500801	40*40 花角	9.00
GN2241	45*20	3.00
	45X20 角	2.0
GN1351	48*14 角	*
SL005	48*16 角	3.00
GN2078	49.8*49.8 花角	3.80
GN1182	50*5 角	0.80
	50*6.2 角铝	1.20
GN2000	50.13 角铝	2.00
	50*30	2.00
		3.00
GN0091	50*30 角	3.00
	50*50	2.00
		2.50
		3.00
		4.00
GN0215		5.00
	52*25	3.00
	53*22 角	3.00
	55*50 角	4.80
GN0404	55*55 花角	2.20
	60*26 角	2.80
	60*60 角	10.00
	73*50 角	6.00
	70*70 角	8.00
	75*20 角铝	2.00
	75*25 角铝	3.00
	76*50 角	6.00
GN0355	90*20 角铝	5.00
	98*28	3.00
GN1042	100*50	4.00
GN1041	100*80	4.00
GN2681	101*11 角铝	1.00

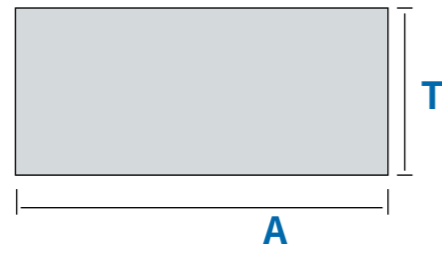

图号	规格 (mm) 宽	壁厚 (mm)
GN0214	6	2
	10	5
	15	2
GN0415	15	3
GN2756	15	7
	17	13
	19	3.8
GN0807	20	1.5
		2
		3
		4
	25	2
		2.5
		3
		4
		5
	30	1.5
		2
		3
		4
		5
	35	5

图号	模具编号	厚度		
GN0635	40	3		
		4		
		5		
GN0631	46	3.5		
	50	2		
		3		
		4		
		5		
		6		
		GN0631		6
		GN0884		15
GN0092 改	60	2.9		
		3		
		5		
		6		
		10		
		12		
GN0624	80	4		
		12		
GN0885	90	6		
GN0259 改	100	5		
		6		
	120	5		
		6		
	150	6		
	200	8		
10				