

CLS-73/65
FOLDING DOOR SYSTEM

CLS-73/65 折疊門系統

www.clayson.cn

Breaking through conventions and creating a new spatial pattern, Clayson folding doors make a stunning debut. The overall design follows the principles of simplicity, aesthetics, and coordination. The principle of uniform lines and extremely narrow borders introduces endless lighting and circulating air into the space.

衝破常規，再造空間新格局，Clayson 折疊門整體設計遵循簡潔至上、美觀協調、線條均勻、邊框極窄的原則，為空間引入無盡的採光與流通的空氣。





Between folds, define a new dimension of spatial aesthetics

The CLS-73/65 series concealed and exposed folding door system satisfies your dual imagination of quality and design.

折疊之間，定義空間美學新維度

CLS-73/65 系列隱藏式 & 外露式折疊門系統，滿足你對品質與設計的雙重想象。

高承重和輕量化控制，該系統特別適用於大面積滑動門

High load-bearing and light control, the system is especially suitable for large area sliding doors



Safe and stable
安全穩定



Quick installation
快速安裝

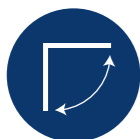

Easy operation
操作方便

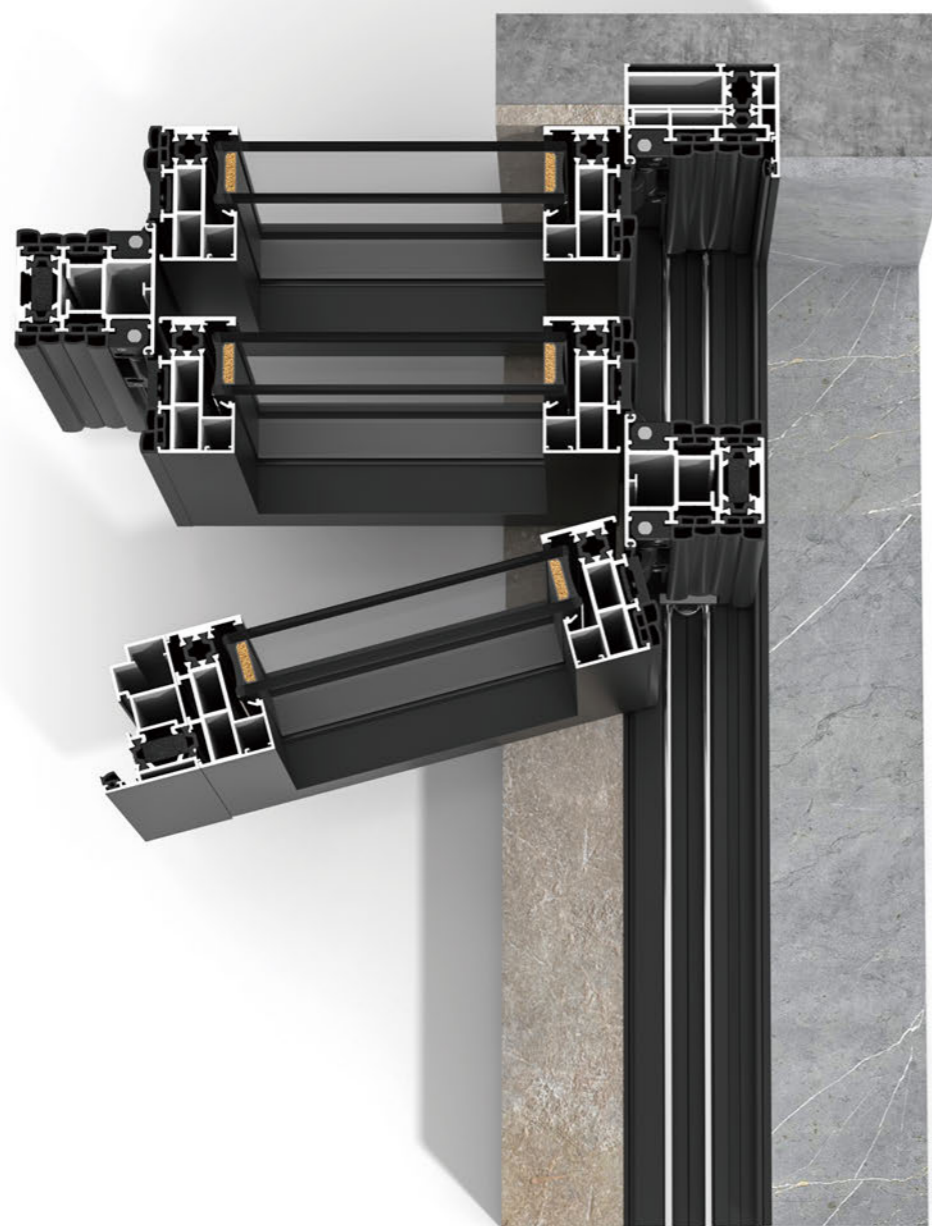

FOLDING DOOR SYSTEM

CLS-73/65 系列隱藏 & 外露合頁折疊門系統

本折疊門系統採用隱藏式平面拉手配合半自動鎖閉系統，打破了傳統扁把手鎖閉固有方式，全系列標配不銹鋼滑輪，304/420 滑輪殼體及軸承在表面鈍化處理下增加了耐腐蝕性能。

This folding door system adopts a hidden flat handle combined with a semi-automatic locking system, breaking the traditional flat handle locking method. The entire series comes standard with stainless steel pulleys, and the 304/420 pulley housing and bearings have increased corrosion resistance under surface passivation treatment.

隱藏合頁折疊門系統採用全新的合頁隱藏結構設計，在現有的技術上提升了折疊門整體的密封性能，通過設計在門扇上下錯位搭接的密封膠條及門扇之間三道密封膠條來實現高水密性、氣密性的性能指標。

The hidden hinge folding door system adopts a brand new hinge hidden structure design, which improves the overall sealing performance of the folding door on existing technology. By designing sealing strips that are staggered and overlapped on the top and bottom of the door leaf and three sealing strips between the door leaves, high water tightness and air tightness performance indicators are achieved.

外露合頁折疊門系統在隱藏合頁折疊門系統基礎上，實現 80% 的型材及五金共用性，全新原創火車輪滑輪組設計大大提升了折疊推拉的順暢性，門扇下方拋棄現有的增加鋁型材擋邊進行隱藏滑輪組的結構，利用特殊角碼解決了隱藏滑輪組的隱藏問題

The exposed hinge folding door system achieves 80% sharing of profiles and hardware on the basis of the hidden hinge folding door system. The new original design of the train wheel slide system greatly improves the smoothness of folding and sliding. The existing structure of adding aluminum profile ribs to hide the pulley system under the door leaf is abandoned, and a special corner code is used to solve the problem of hidden pulley system.

Innovative hardware design

In the early stages of product design, Clayton's designers considered how to integrate "safety" and "stability" into the structure of hardware products. Our design team studied a large number of well-known domestic and foreign brand folding door products, and summarized that simplicity, atmosphere, and beauty are the first elements. With the advancement of safety, smoothness, and performance, we have created a classic work of hidden flat handle locks. Combined with the structural application of stainless steel train pulleys, we fully embody the theme of systematic design and redefine the new standard of smooth aesthetics for folding doors.

創新性五金結構設計，確保安全穩定運行

Clayson 的設計師在產品設計初期，就考慮了如何將“安全”、“穩定”融入到五金產品結構中，我們的設計師團隊研究了大量國內外知名品牌的折疊門產品，總結出以簡潔、大氣、美觀為第一要素，在安全、順暢、性能的提前下，造就了隱藏式平面拉手鎖的經典之作，結合不銹鋼火車滑輪的結構應用，將系統性設計這一主題體現得淋漓盡致，重新定義折疊門的流暢美學新標準。



Three seals, with no gaps at all
 Designed with three sealing strips,
 Simultaneously working with the track seal,
 it improves the thermal
 performance and sealing of the entire door.

三道密封，絲毫密縫
 采用三道密封膠條設計，
 與軌道密封同時作用，提高整門的熱工性與密封性。

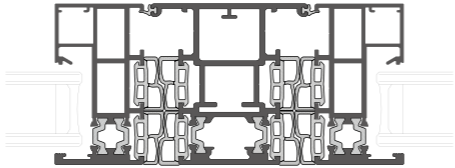

HIDDEN HANDLE

隱藏平面拉手
極致美觀 輕鬆操控

The door leaf is installed with a hidden flat handle,
By combining a completely new structural design with a semi-automatic locking system,
The combination of handle and lock functions makes it easy to open and close the
folding door switch.

門扇安裝隱藏平面拉手，
通過全新的結構設計搭配半自動鎖閉系統，
綜合拉手與鎖體功能，使折疊門開關操作輕鬆啓閉。

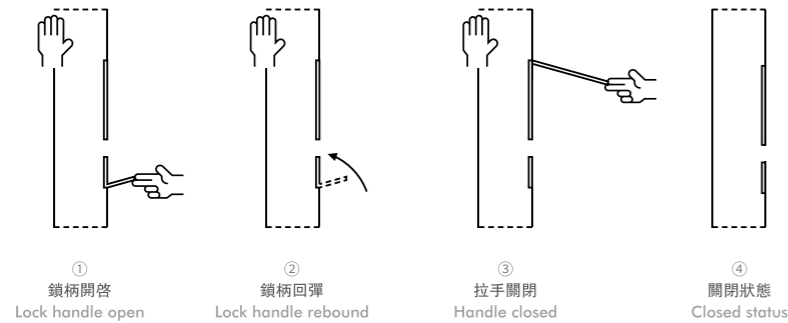

The design of the hinge rubber strip provides an additional layer of protection for the seal, Sealed in all directions without dead corners, making it impossible for wind and rain to seep through.

合頁膠條設計，讓密封多一道保障
全方位無死角密封，讓風雨無處可滲。



Automatic rebound pin design

Innovative and simplified design, abandoning cumbersome structures, utilizing the inner cavity of profiles for easy manufacturing and installation of the pipe body, Collaborative planar handle simplifies the tedious locking operation, and the door leaf can be automatically locked by pulling once it is opened.

自動回彈插銷設計

創新性簡化設計，拋棄繁瑣結構，利用型材內腔為管體輕鬆制造安裝，協同平面拉手，簡化繁瑣鎖閉操作，門扇的開啓後一拉實現自動鎖閉。

Anti pinch is safer

Install sedan grade composite foam strips in the gap between the door leaf and the center pillar;
Even if your fingers extend into the gaps between the door leaves when the door leaves are closed, it can effectively prevent accidental finger injuries.

防夾手更安全

門扇與中柱間隙安裝轎車級別復合發泡膠條；
在門扇關閉時即使手指伸進門扇之間的縫隙也能有效避免手指意外夾傷。

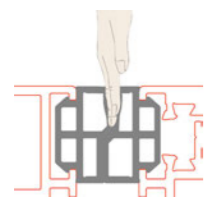

Clayson

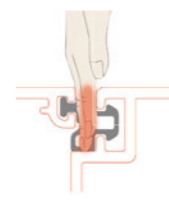

others



Hidden hanging wheel

Innovative spring soft connection hanging pulley design, with auxiliary load-bearing hanging pulley subjected to force, The lower pulley support is mainly subjected to force, and the upper and lower pulleys work together smoothly without obstruction. Innovatively subverting the traditional design of hanging wheel screw connection seat, simple, safe, efficient, and stable.

隱藏式吊輪設計

創新性彈簧軟連接上吊滑輪設計，上輔助承重吊輪受力，下滑輪支撐主要受力，上下滑輪協同運作，順暢無阻。創新性顛覆傳統的吊輪螺桿連接座設計，簡單、安全、高效、穩定。



High performance load-bearing pulley system

Originality applies the train wheel structure to the folding door pulley system, adding brush cleaning function to enhance the smoothness of folding and sliding. Adopting stainless steel 420 bearings and stainless steel 304 pulley housing, and then undergoing surface passivation treatment, the rust resistance and corrosion resistance of the pulley are improved by more than 90%, far exceeding peer products.

高性能承重滑輪組

原創性將火車輪結構應用在折疊門滑輪組中，增加毛刷清理軌道功能，提升折疊推拉的順暢性。採用不銹鋼 420 軸承及不銹鋼 304 滑輪殼體，再經過表面鈍化工藝處理，將滑輪的防銹性及耐腐蝕性提升 90% 以上，遠超同行產品。



Original Design of Avoidance Slot for Pulley System
 Using special corner codes to create hidden clearance slots for the pulley system after 45 degree angle grouping of the door leaf
 Simplified design to achieve higher sealing performance

滑輪組避空槽位原創性設計
 利用特殊角碼實現門扇 45 度組角後形成滑輪組的隱藏避空槽位
 簡單化的設計從而達到更高密封性能

Innovative design of water blocking rubber strip
 Clever water blocking rubber strip design adds an additional sealing guarantee to the folding door;
 Prevent rainwater from flowing back into the room through the gap mesh.

創新擋水膠條設計
 巧妙的擋水膠條設計，為折疊門增加多一道密封保障；
 杜絕雨水通過縫隙網室內倒灌。

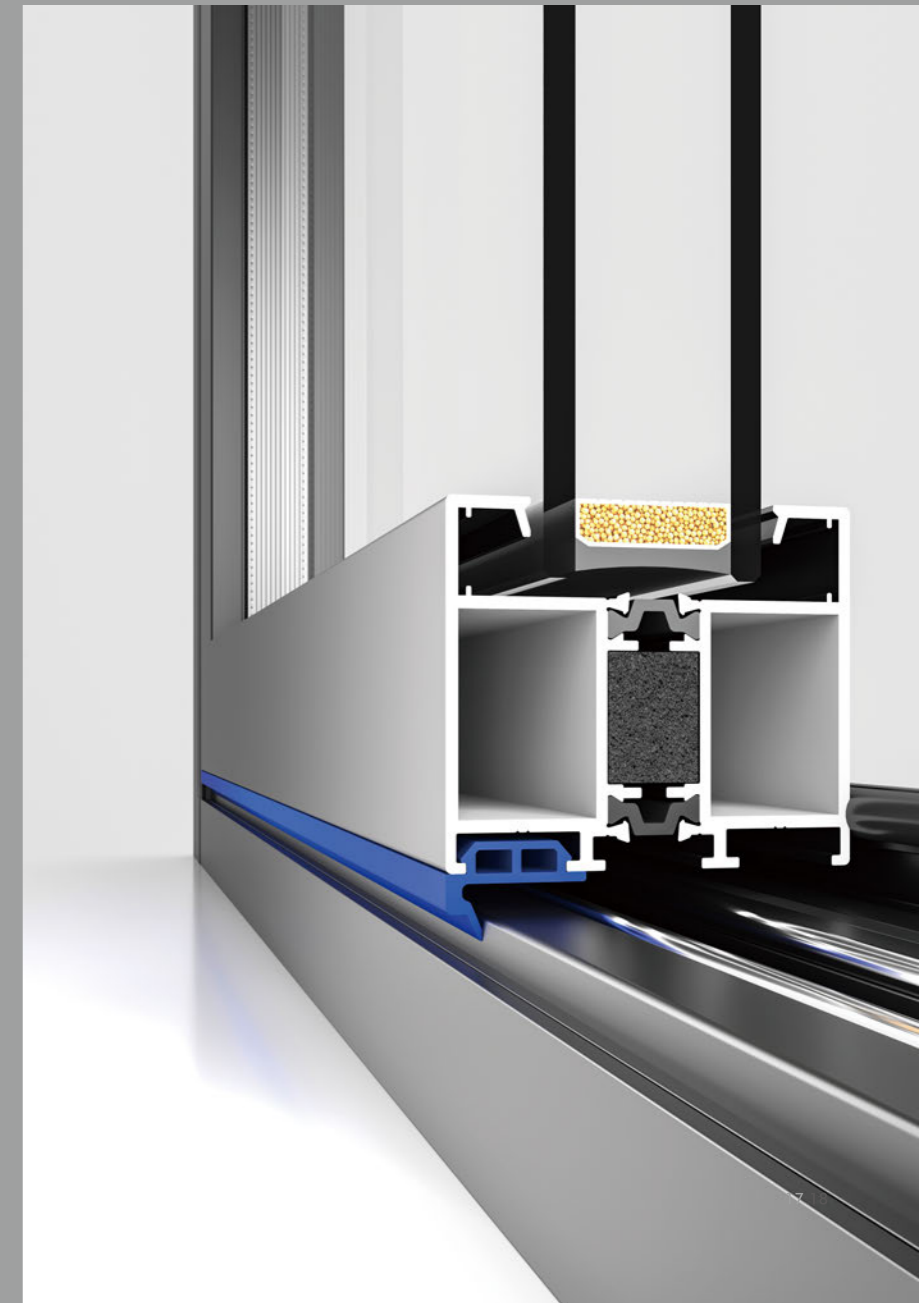



Easy folding, full frame free space

CLS-73/65 series folding door system can meet the application needs of various scenarios, breaking through the limitations of folding in the past, not only creating unique designs for spaces but also providing good environmental requirements for interiors.

輕鬆折疊，全畫幅自由空間

CLS-73/65 系列折疊門系統可滿足各種場景的應用需求，突破以往折疊的限制，不僅為空間創造獨特的設計而且為室內提供了良好的環境需求。

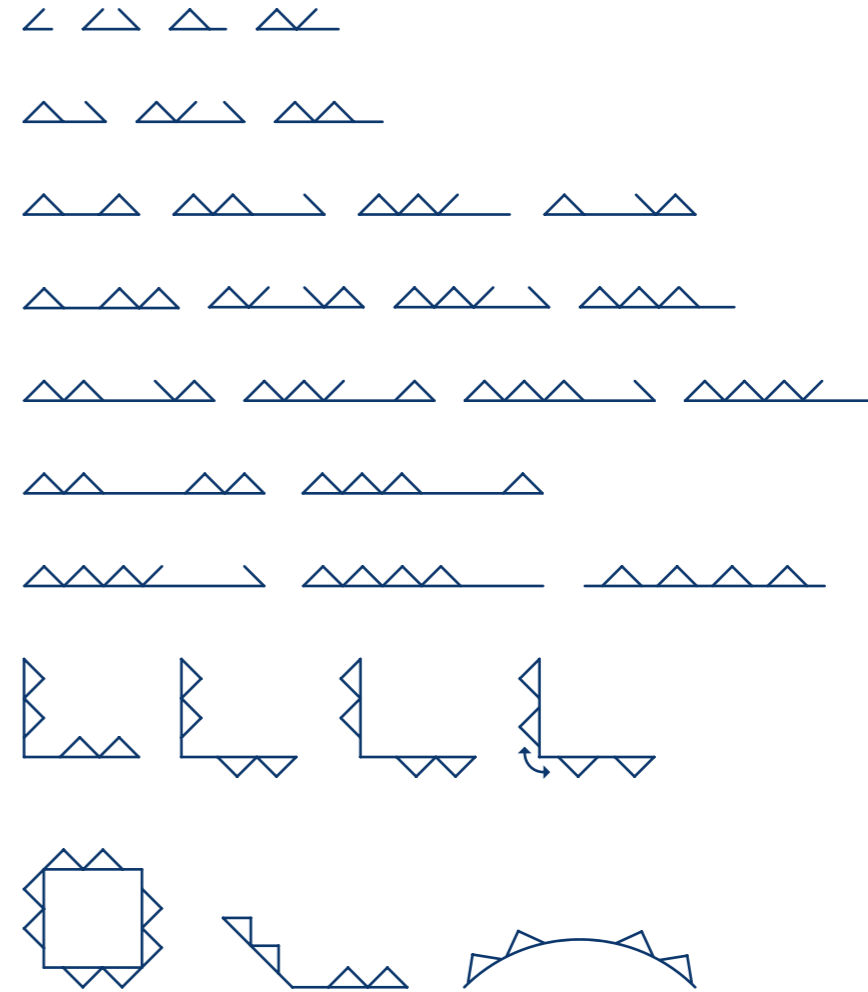

73/65 折疊門系統設計方案 (隱藏合頁)

Hidden Hinge(Non-Broken Bridge Scheme)
隱藏合頁 (非斷橋方案)

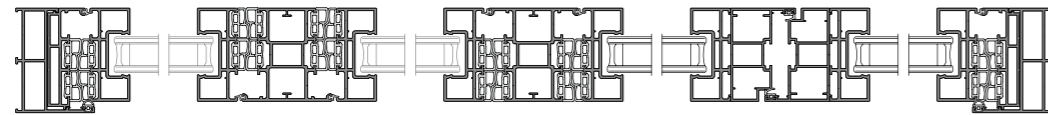

Hidden Hinge(Broken Bridge Scheme)
隱藏合頁 (斷橋方案)

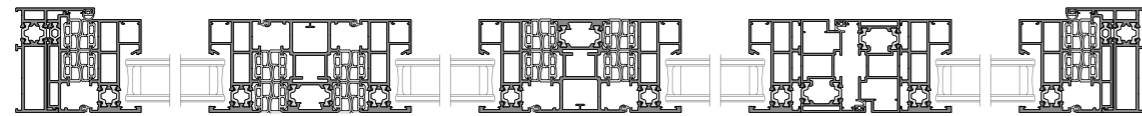

Hidden Hinge(Track Plan)
隱藏合頁 (軌道方案)

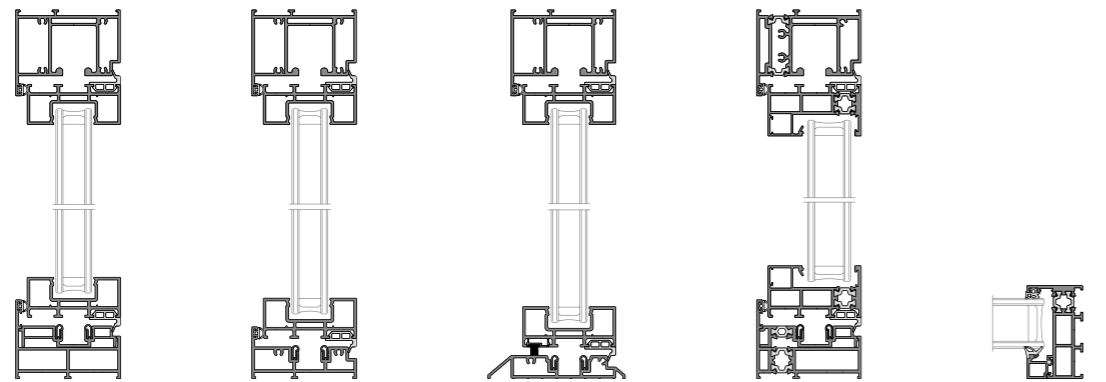

High Orbit Scheme
高軌道方案

Low Orbit Scheme
低軌道方案

Accessible Orbit Scheme
無障礙軌道方案

High Orbit Scheme
(Broken Bridge)
高軌道方案 (斷橋)

Line Pressing Scheme
(Broken Bridge)
壓線方案 (斷橋)

73/65 折疊門系統設計方案 (外露合頁)

Exposed Hinge(Non-Broken Bridge Scheme)
外露合頁 (非斷橋方案)

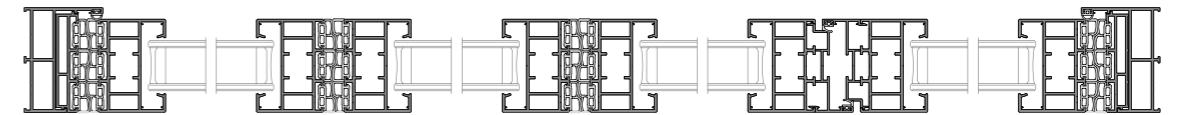

Exposed Hinge(Broken Bridge Scheme)
外露合頁 (斷橋方案)

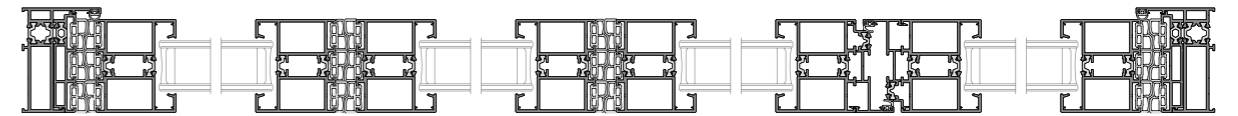

Exposed Hinge(Track Plan)
外露合頁 (軌道方案)

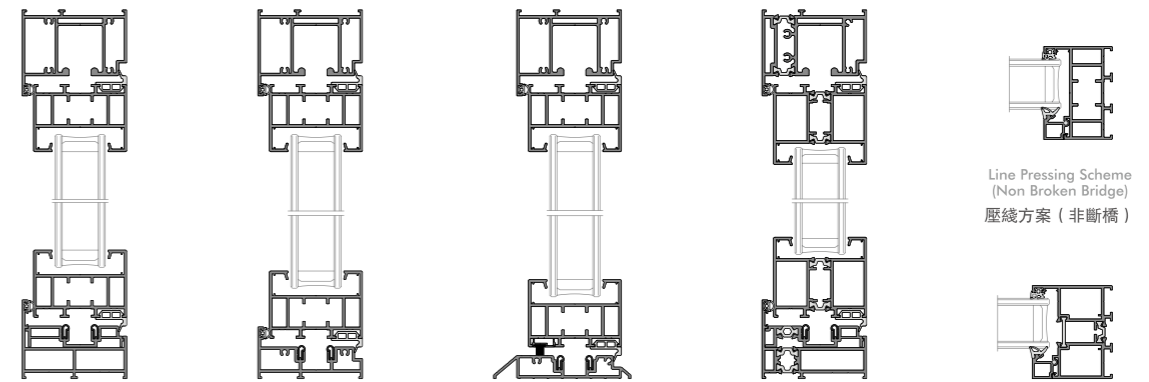

High Orbit Scheme
高軌道方案

Low Orbit Scheme
低軌道方案

Accessible Orbit Scheme
無障礙軌道方案

High Orbit Scheme
(Broken Bridge)
高軌道方案 (斷橋)

Line Pressing Scheme
(Non Broken Bridge)
壓線方案 (非斷橋)

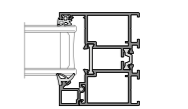

Line Pressing Scheme
(Broken Bridge)
壓線方案 (斷橋)

Technical Parameters Table of Hidden Hinge Folding Door System

隱藏合頁折疊門系統技術參數表

參數 Parameter	洞口最大寬度 Maximum width of the opening	洞口高度範圍 Height range of the opening	單扇寬度範圍 Single fan width range	合頁標配數量 Standard quantity of hinges	單扇最大承重 Maximum width of the opening	型材壁厚 Profile thickness
上導輪下承重 Upper guide wheel and lower load-bearing capacity	800–10000mm	600–2500mm	450–800mm	3	75kg	2.0mm (斷橋) Broken bridge 1.8mm (非斷橋) Non broken bridge
上吊輪下承重 Upper suspension wheel and lower load-bearing capacity	800–20000mm	600–3200mm	450–950mm	4–5	120kg	2.0mm (斷橋) Broken bridge 1.8mm (非斷橋) Non broken bridge

警告：本折疊門請根據國家標準中的有關規定進行制作及安裝，違反相關標準出現的相關安全事故由責任人自行承擔一切法律後果。
Warning: Please make and install this folding door according to the relevant regulations in the national standards. Any safety accidents that violate the relevant standards shall be borne by the responsible person for all legal consequences.

Technical Parameters Table of Exposed Hinge Folding Door System

外露合頁折疊門系統技術參數表

參數 Parameter	洞口最大寬度 Maximum width of the opening	洞口高度範圍 Height range of the opening	單扇寬度範圍 Single fan width range	合頁標配數量 Standard quantity of hinges	單扇最大承重 Maximum width of the opening	型材壁厚 Profile thickness
上吊輪下承重 Upper suspension wheel and lower load-bearing capacity	800–20000mm	600–3200mm	450–950mm	3–4	120kg	2.0mm (斷橋) Broken bridge 1.8mm (非斷橋) Non broken bridge

警告：本折疊門請根據國家標準中的有關規定進行制作及安裝，違反相關標準出現的相關安全事故由責任人自行承擔一切法律後果。
Warning: Please make and install this folding door according to the relevant regulations in the national standards. Any safety accidents that violate the relevant standards shall be borne by the responsible person for all legal consequences.

Performance Specifications of Hidden Hinge Folding Door System

隱藏合頁折疊門系統性能參數表

系列 Series	氣密性能 Air tightness	水密性能 Water tightness	抗風壓性能 Wind Load Resistance	保溫性能 (K 值) Thermal insulation (K)	隔音性能 (dB) Soundproofing (dB)
斷橋 Broken bridge	8 級 Level 8	5 級 Level 5	9 級 Level 9	2.6W/(m ² · K)	30
非斷橋 Non broken bridge	8 級 Level 8	5 級 Level 5	9 級 Level 9	2.9W/(m ² · K)	35

備注：相關性能會因門型分格、面積、玻璃不同而有所差異，以上為理論數據，具體請以實際相關檢測數據為準！
Note: The relevant performance may vary depending on the door type, area, and glass. The above is theoretical data, please refer to the actual relevant testing data for details!

玻璃槽口 Glazing rebate	玻璃尺寸 Standard quantity of hinges	中空百葉 Hollow blinds	任意折數 Any number of folds	無立柱轉角 Corner without pillars	自由折疊 Free folding	高 / 低 / 無障礙軌道 High/Low/Barrier free Track	外觀五金顏色 Appearance hardware color
36mm (斷橋) Broken bridge	5+22A+5	支持 Support	支持 Support	支持 Support	支持 Support	支持 Support	銀色 / 黑色 / 訂色 Silver/Black/Customized
10/28mm (非斷橋) Non broken bridge	6/5+15A+5						
36mm (斷橋) Broken bridge	5+22A+5	支持 Support	支持 Support	支持 Support	支持 Support	支持 Support	銀色 / 黑色 / 訂色 Silver/Black/Customized
10/28mm (非斷橋) Non broken bridge	6/5+15A+5						

玻璃槽口 Glazing rebate	玻璃尺寸 Standard quantity of hinges	中空百葉 Hollow blinds	任意折數 Any number of folds	無立柱轉角 Corner without pillars	自由折疊 Free folding	高 / 低 / 無障礙軌道 High/Low/Barrier free Track	外觀五金顏色 Appearance hardware color
39mm (斷橋/非斷橋) Broken bridge/ Non broken bridge	5+25A+5	支持 Support	支持 Support	支持 Support	支持 Support	支持 Support	銀色 / 黑色 / 訂色 Silver/Black/Customized

Performance Specifications of Exposed Hinge Folding Door System

外露合頁折疊門系統性能參數表

系列 Series	氣密性能 Air tightness	水密性能 Water tightness	抗風壓性能 Wind Load Resistance	保溫性能 (K 值) Thermal insulation (K)	隔音性能 (dB) Soundproofing (dB)
斷橋 Broken bridge	8 級 Level 8	5 級 Level 5	9 級 Level 9	2.6W/(m ² · K)	30
非斷橋 Non broken bridge	8 級 Level 8	5 級 Level 5	9 級 Level 9	2.9W/(m ² · K)	35

備注：相關性能會因門型分格、面積、玻璃不同而有所差異，以上為理論數據，具體請以實際相關檢測數據為準！
Note: The relevant performance may vary depending on the door type, area, and glass. The above is theoretical data, please refer to the actual relevant testing data for details!

CLS-63/45
FOLDING WINDOW SYSTEM

CLS-63/55 折叠窗系统

www.clayson.cn

Breaking boundaries, reshaping perspectives, and innovatively designing extremely narrow folding windows are provided by the Clayson system.

打破邊界，重塑視野，創新設計的極窄扇折疊窗由 clayson 系統提供，
由內到外實現了簡潔、美觀、均勻、極窄的線條，為空間提供了最大的采光及通風效果。



With the Clayson system, your balcony can be wider and more ventilated; Extremely narrow folding windows allow for a wider view than ever before; Modern minimalist line design, integrating efficient sound insulation and thermal insulation performance, brings home and nature closer together.

有了 clayson 系統，你的陽臺，可以更寬廣、更通風透氣；極窄扇折疊窗，讓視野從未如此開闊；現代簡約綫條設計，融合高效隔音與保溫性能，家與自然更進一步。



FLAT HIDDEN HANDLE

創新性雙齒輪 平面隱藏式拉手

The innovative dual gear drive flat concealed handle is equipped with a child safety lock, significantly enhancing the safety and functionality of the product. Fluorocarbon paint spraying surface treatment process, the product's weather resistance and corrosion resistance are higher than national standards, easy one handed opening and closing operation, and automatic rebound.

創新性的雙齒輪驅動平面隱藏拉手，配備了兒童安全鎖，顯著增強產品的安全性與功能性。氟碳油漆噴塗表面處理工藝，產品的耐候性以及耐腐蝕性高于國家標準，單手輕鬆啓閉操作，自動回彈。

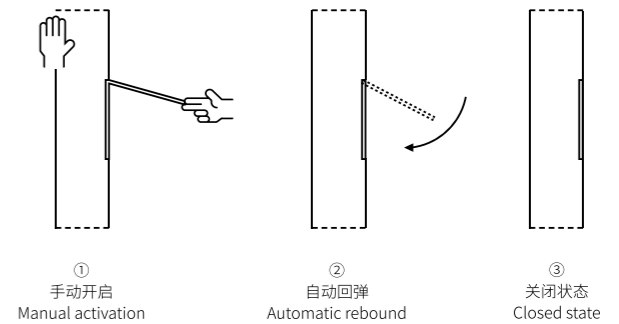



32mm extremely narrow window sash with anti pinch design for greater safety

Adopting the ultimate minimalist design concept, the folding window sash has an ultra narrow frame of only 32 millimeters, which is beautiful and generous. It is also equipped with anti pinch rubber strips between the leaves to ensure safe use.

32mm 極窄窗扇，防夾手設計更安全

採用極致簡約的設計理念，折疊窗扇擁有僅 32 毫米的超窄邊框，美觀大方，更在扇葉之間配備了防夾手膠條，確保使用安全。

Innovative hardware design

Clayton's designers defined a label of "extremely narrow" in the early stages of product development. How to install minimalist style hardware on the extremely narrow fan design without affecting normal operation and use was a challenge. Our designers designed the profile structure with an eccentric glass groove, reserved a cavity for installing hardware on the interior surface, and further designed the hidden flat handle lock structure of the folding door on the folding window with a child lock function. The slot of the locking hardware is designed as a European standard slot, and the limited size of the slot is utilized to intricately design the locking pins for the upper and lower automatic locks. The freely folding pulley system adopts the principle of left-right and up-down balanced support, and incorporates "safety" and "stability" into the hardware product structure, creating an innovative balanced pulley system and redefining the new standard of smooth aesthetics for folding windows.

創新性五金結構設計，確保安全穩定運行

Clayton 的設計師在產品立項初期，定義了一個標籤“極窄”，如何在極窄扇設計上安裝極簡風格五金又不影響正常的操作使用，這是一個難題，我們設計師在設計型材結構上把玻璃槽口偏心設計，室內面預留出安裝五金的腔體，將折疊門的隱藏式平面拉手鎖結構再設計到折疊窗上面并增加兒童鎖功能。鎖閉五金的槽口設計成歐標槽口，利用槽口有限的尺寸，將上下自動鎖的插銷設計得非常精巧。自由折疊的滑輪組採用左右、上下平衡支撐原理，並將“安全”“穩定”容入到五金產品結構中，造就了創新性的平衡滑輪組，重新定義折疊窗的流暢美學新標準。



AUTOMATIC PIN DESIGN

創新性歐標槽口 自動插銷設計

The main body of the pin is made of DuPont imported polyoxymethylene composite material, which has higher stability and wear resistance. The groove surface is equipped with a protective cover plate to prevent prying, and the minimalist design ensures safety and efficiency.

插銷主體採用杜邦進口聚甲醛復合材料，產品穩定性更高，更耐磨，槽口表面增加防護蓋板安全防撬，極簡設計，安全高效。



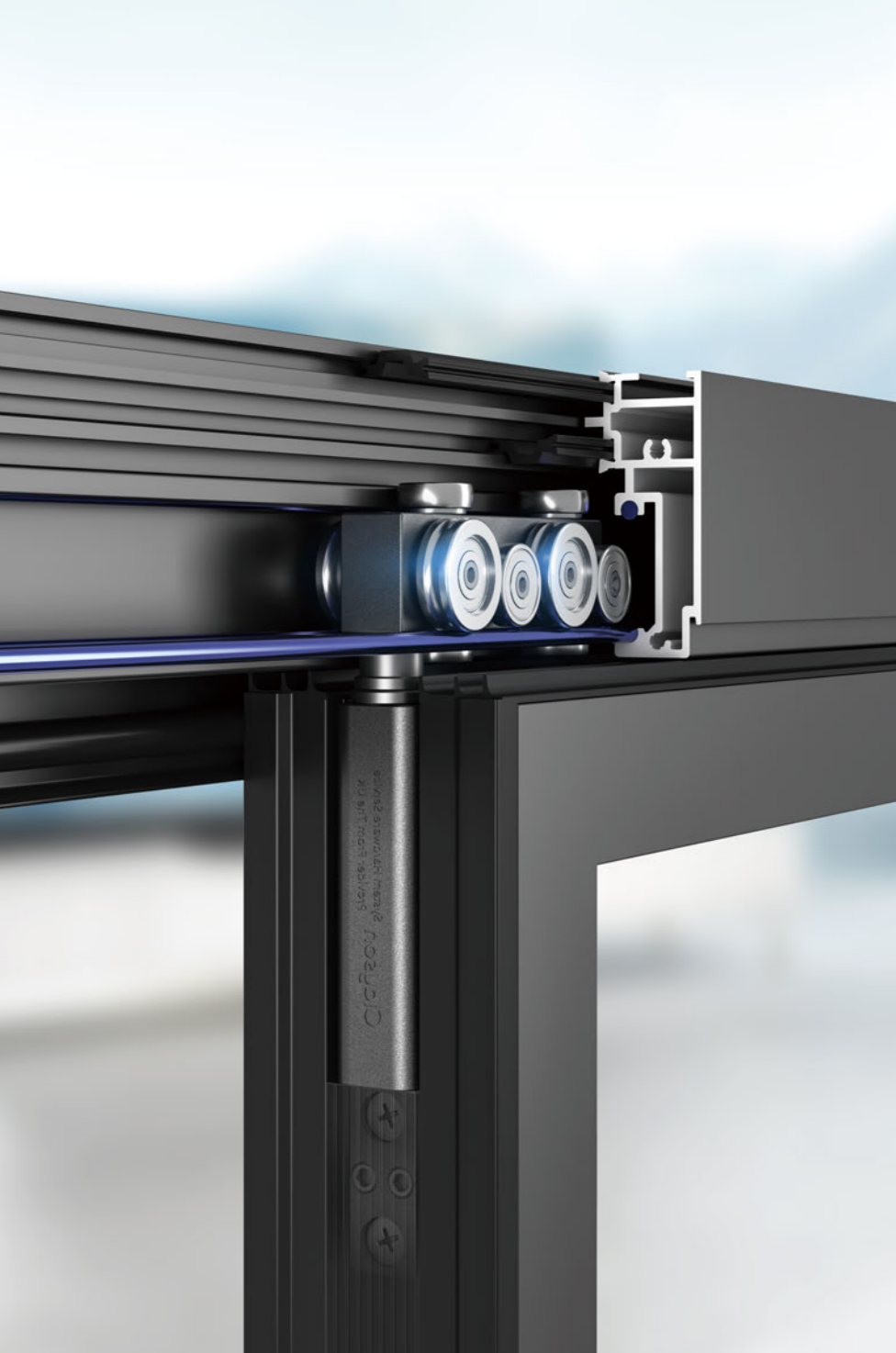

Innovative free folding balance pulley assembly
 創新性自由折疊平衡滑輪組件

Innovative free folding balanced sliding component. Adopting a balanced design with multiple pulleys and guide wheels, effectively preventing the pre tilting phenomenon of windows when opened, ensuring compliance and operability. The bearing wheel is made of stainless steel 420 material and passivated, which can maintain good rust prevention performance even after long-term use in humid and chemically corrosive environments.

創新性自由折疊平衡滑動組件。採用多滑輪和導向輪均衡設計，有效防止窗戶在開啓時的預傾現象，確保規定性和可操作性。軸承輪採用不銹鋼 420 材質及鈍化處理，在潮濕和化學腐蝕環境中長時間使用仍能保持良好的防銹性能。



SEAL DESIGN

The upper and lower tracks adopt a multi-channel sealing design, combined with free folding and fixed folding edge rubber strips; The outdoor side rubber strip adopts a slanted curved surface design to ensure effective drainage and prevent water accumulation.

上下軌道採用多道密封設計，配合自由折疊與固定折疊擋邊膠條；
室外側膠條採用斜弧面設計，確保有效排水，防止積水。



Multi channel sealing design for smooth drainage
多道密封設計 順暢排水 卓越密封



Open the fan position, fix the fan, and use the same material for the lower fixed frame. The material cost is cheaper than conventional casement windows, saving materials. Innovative design, shared frame, saving materials and reducing costs, combining quality and cost-effectiveness, brings stronger market competitive advantages.

開啓扇位置，固定扇，下固定邊框全部共用一支材料，材料成本便宜過常規的平開窗，省料，創新設計，共用邊框，省料降本，兼具品質與性價比，帶來更強的市場競爭優勢。

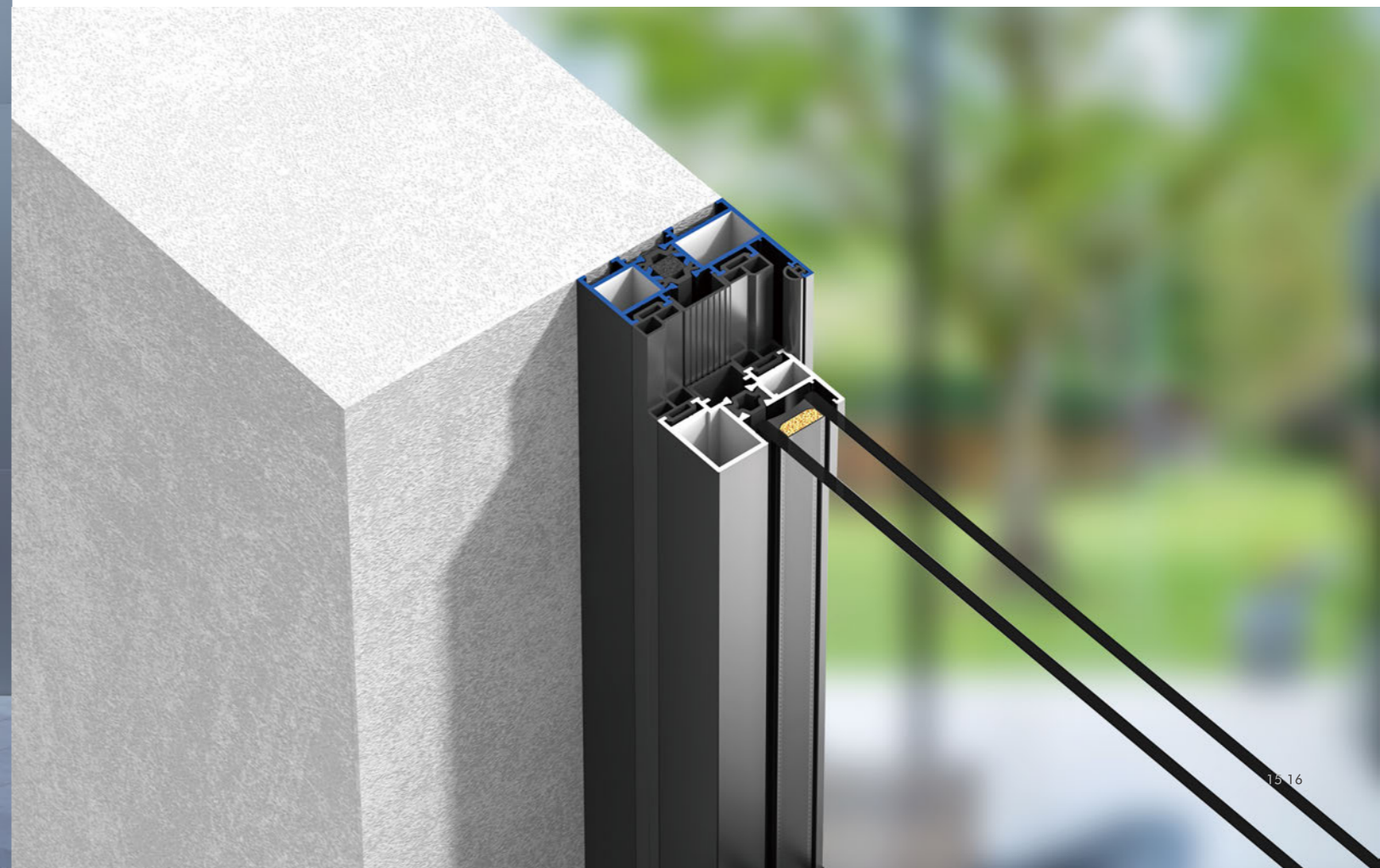

Strengthen armrest design, effectively resist wind pressure, iterate existing sliding windows,
Competitive advantage comparison: Sliding windows can provide extensive ventilation and a wide field of view when opened

加强扶手設計，有效抵抗風壓，迭代現有推拉窗，
競爭優勢對比推拉窗開啓後能大面積通風，視野開闊。

Strengthen the design of handrails to resist wind pressure





Meet the needs of multiple scenarios and bring a more comfortable and convenient experience:

滿足多場景使用需求，帶來更加舒適與便捷的體驗：

63/55 Folding window system design scheme (Non-broken bridge)

63/55 折疊窗系統設計方案（非斷橋）

- The current narrowest fan width on the market is suitable for outdoor balcony folding window design, with a visible surface of only 77mm.
 - The most distinctive folding window currently on the market is equipped with a child safety lock hidden handle and automatic locking function.
 - Large glass hollow design, can be equipped with manual hollow louver glass.
 - Minimalist profile scheme, with a basic configuration of 8 materials for non broken bridges and 10 materials for broken bridges, and a theoretical material consumption of no more than 7.5kg per square meter for an opening of 6 square meters.
 - Strengthening the design scheme of the horizontal armrest and the central column effectively enhances the overall wind pressure resistance performance of the folding window
- 市場上目前最窄扇料寬度的適合戶外封陽臺的折疊窗設計，可視面僅為 77mm。
 - 市場上目前最具有特色的折疊窗，配備兒童安全鎖隱藏式拉手及自動插鎖閉功能。
 - 大玻璃中空設計，可配備手動中空百頁玻璃。
 - 極簡的型材方案，基本配置下非斷橋 8 個材料，斷橋 10 個材料，洞口 6 平方算理論每平方米材料用量不超過 7.5kg。
 - 加強中橫扶手及加強中柱設計方案，有效增加折疊窗整體的抗風壓性能

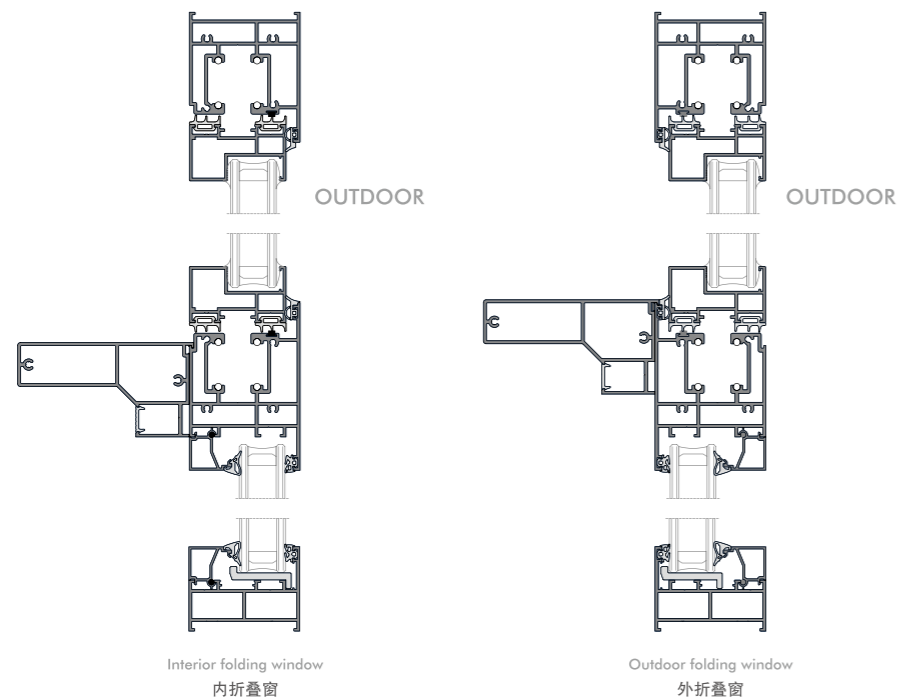
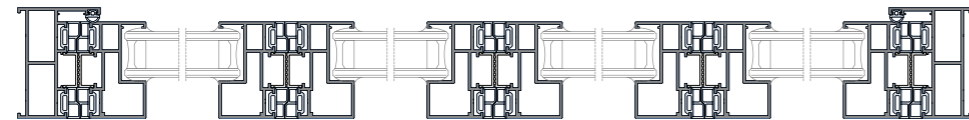

63/55 Folding window system design scheme (broken bridge)

63/55 折疊窗系統設計方案（斷橋）

- A drying rack design that conforms to Chinese characteristics and meets different user needs.
 - Can be paired with externally installed electric roller shutter mesh and manually folded mesh, effectively preventing mosquitoes and increasing breathability.
 - Specially designed border sealing strip and structure, inclined double contact extrusion sealing structure design makes the gap between the window sash and the frame tighter, matching the track the internal brush and overlapping sealing strip effectively enhance the sealing performance of the folding window.
 - The vertical isotherm structure design of the broken bridge effectively blocks indoor and outdoor energy exchange, making it more insulated in winter and more energy-efficient in summer
 - Free folding, traditional border connection folding, upper fixation, lower fixation, inner folding, outer folding, no column corner folding window, all solutions can be easily implemented.
- 符合中國特色的晾衣架設計，滿足不同的用戶需求。
 - 可搭配外附安裝的電動卷簾紗網及外附手動折疊紗網，有效防蚊蟲增加透氣性能。
 - 特殊設計的邊框密封膠條及結構，斜面雙接觸擠壓密封結構設計使得窗扇與框之間的縫隙更緊密，配合軌道內的毛刷及內搭接密封膠條，有效提升了折疊窗的密封性能。
 - 斷橋垂直等溫綫結構設計，有效阻隔室內外能量交換，冬天更保溫，夏季更節能。
 - 自由折疊、傳統邊框連接折疊、上固定、下固定、內折疊、外折疊、無立柱轉角折疊窗，全部方案可以輕鬆實現。

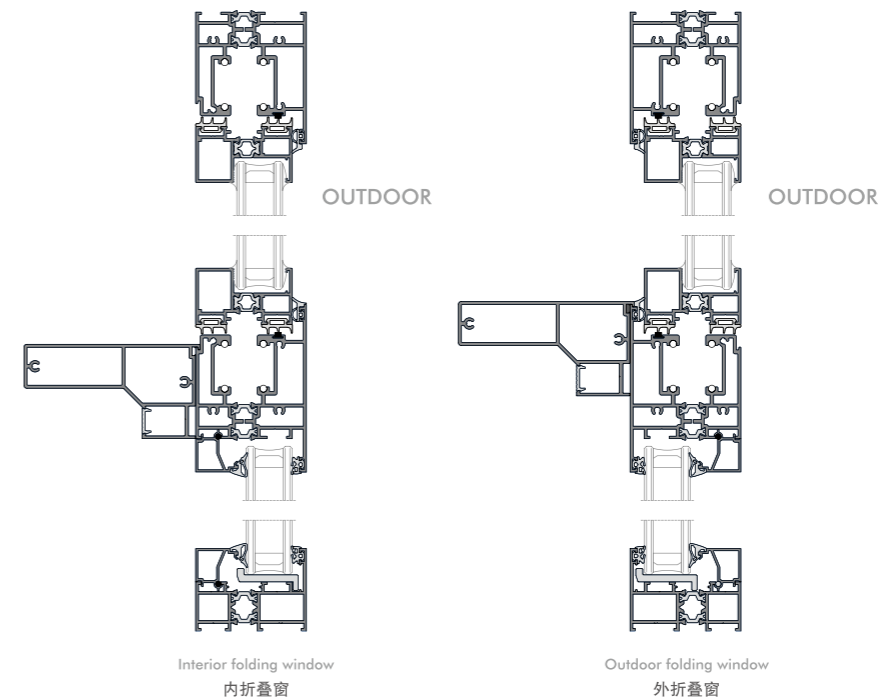
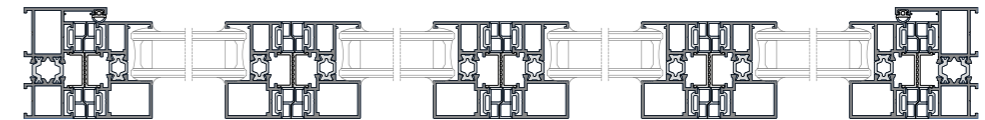



Vertical design of isothermal lines for broken bridge profiles effectively isolates heat

斷橋型材等溫綫垂直設計，有效隔阻熱量

Cleverly integrated with a drying rack design, the lower fixed scheme is flexible and adaptable to various types of clothes. Installation requirements to meet the specific needs of different customer groups.

下固定方案巧妙集成晾衣架設計，靈活適應多種安裝需求，滿足不同客戶群體的具體要求。







折疊方式 / Folding method

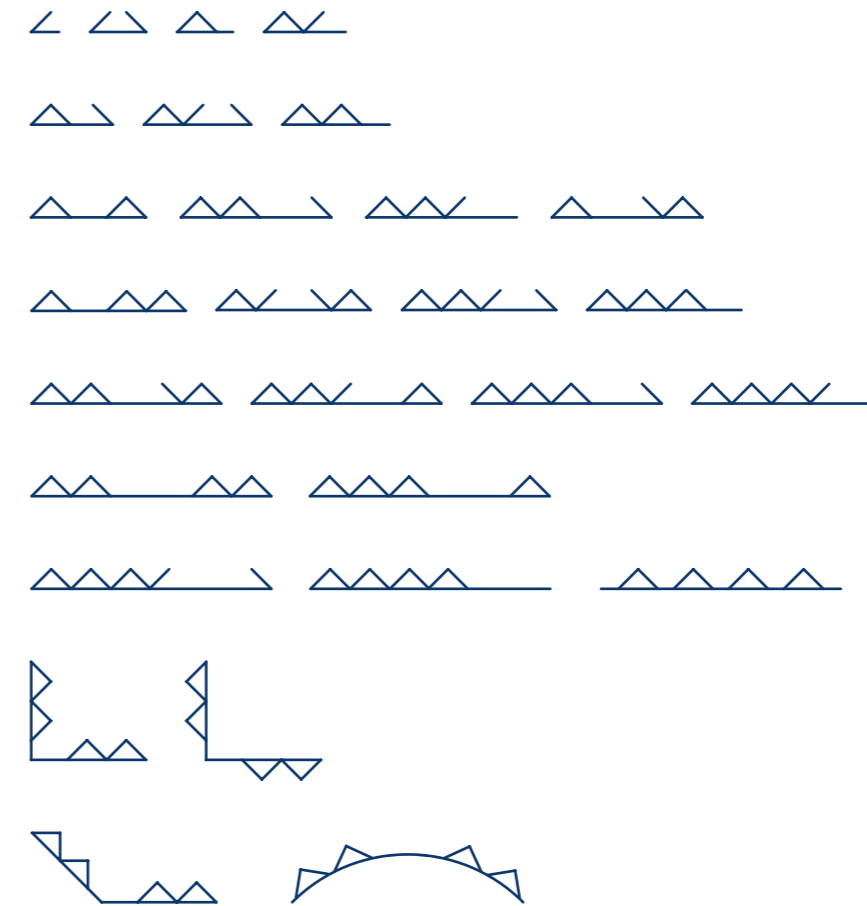

Free folding+fixed traditional folding, one type of profile, multiple methods
Switch between internal and external folding freely

自由折疊 + 固定傳統折疊一種型材多種做法
內折疊 + 外折疊隨意切換

Standard version folding window system configuration table

標準版折疊窗系統配置表

洞口最大寬度 Maximum width of the opening	洞口最大高度 Maximum height of the opening	自由折疊單扇最大承重 Free folding single fan maximum load-bearing capacity		
6000mm	2800mm	40kg		
開啓扇最大寬度 Maximum width of fan opening	開啓扇最大高度 Maximum height of fan opening	固定折疊單扇最大承重 Fixed folding single fan maximum load-bearing capacity		
600mm	1650mm	60kg		
固定扇寬度分格 Fixed fan width grid	玻璃槽口 glazing rebate	玻璃尺寸 Glass Size		
≥ 1500mm	29.5mmX14mm	5mm+16A+5mm		
中空百葉 Hollow blinds	上 / 下 / 左 / 右固定扇 Up/down/left/right fixed fan	防蚊紗網 Mosquito proof mesh	晾衣架 clothes hanger	內開折疊 / 外開折疊 Folding inside/folding outside
YES	YES	YES	YES	YES

Enhanced Folding Window System Configuration Table

加強版折疊窗系統配置表

洞口最大寬度 Maximum width of the opening	洞口最大高度 Maximum height of the opening	自由折疊單扇最大承重 Free folding single fan maximum load-bearing capacity		
10000mm	3500mm	40kg		
開啓扇最大寬度 Maximum width of fan opening	開啓扇最大高度 Maximum height of fan opening	固定折疊單扇最大承重 Fixed folding single fan maximum load-bearing capacity		
600mm	1650mm	60kg		
固定扇寬度分格 Fixed fan width grid	玻璃槽口 glazing rebate	玻璃尺寸 Glass Size		
≥ 3000mm	29.5mmX14mm	5mm+16A+5mm		
中空百葉 Hollow blinds	上 / 下 / 左 / 右固定扇 Up/down/left/right fixed fan	防蚊紗網 Mosquito proof mesh	晾衣架 clothes hanger	內開折疊 / 外開折疊 Folding inside/folding outside
YES	YES	YES	YES	YES

警告：本折疊窗在樓層超過三層建築中不能選擇外開折疊作為制作方案，請根據國家有關於高層建築窗戶法律條文約束規定進行制作安裝，違反此規定出現的相關安全事故由制作銷售廠家自行承擔一切法律後果。

Warning: External folding cannot be chosen as the production plan for this folding window in buildings with more than three floors. Please follow the relevant laws and regulations on high-rise building windows in the country for production and installation. Any safety accidents that violate this regulation will be borne by the production and sales manufacturer.

Standard version folding window system

標準版折疊窗系統

斷橋系列 Broken Bridge Series				
氣密性能 Air tightness performance	水密性能 Water tightness performance	抗風壓性能 Wind resistance performance	保溫性能 (K 值) Thermal insulation performance (K value)	隔音性能 (dB) Sound insulation performance (dB)
8 級	5 級	8 級	2.6W/(m ² ·K)	30
非斷橋系列 Non Broken Bridge Series				
氣密性能 Air tightness performance	水密性能 Water tightness performance	抗風壓性能 Wind resistance performance	保溫性能 (K 值) Thermal insulation performance (K value)	隔音性能 (dB) Sound insulation performance (dB)
8 級	5 級	8 級	2.9W/(m ² ·K)	35

Enhanced Folding Window System

加強版折疊窗系統

斷橋系列 Broken Bridge Series				
氣密性能 Air tightness performance	水密性能 Water tightness performance	抗風壓性能 Wind resistance performance	保溫性能 (K 值) Thermal insulation performance (K value)	隔音性能 (dB) Sound insulation performance (dB)
8 級	5 級	9 級	2.6W/(m ² ·K)	30
非斷橋系列 Non Broken Bridge Series				
氣密性能 Air tightness performance	水密性能 Water tightness performance	抗風壓性能 Wind resistance performance	保溫性能 (K 值) Thermal insulation performance (K value)	隔音性能 (dB) Sound insulation performance (dB)
8 級	5 級	9 級	2.9W/(m ² ·K)	35

備注：相關性能會因窗型分格、面積、玻璃不同而有所差異，以上為理論數據，具體請以實際相關檢測數據為準！

Note: The relevant performance may vary depending on the window type, area, and glass. The above is theoretical data, please refer to the actual relevant testing data for details!



WeChat



Douyin



Instagram



TikTok



YouTube

克徠森門窗系統有限公司

Clayson Doors and Windows Systems Co., Ltd

克萊德森建築設計有限公司

Clayderson Architectural Design Co., Ltd

地址：中國廣東省佛山市南海區獅山鎮譚邊工業區廣虹路 10 號

電話：+86 0757-85515882 WhatsApp: +86 13392835756

郵箱：clayson.uk@gmail.com

Address: No.10 Guanghong Road, Tanbian Industrial Zone, Shishan Town,
Nanhai District, Foshan City, Guangdong Province, China

Tel: +86 0757-85515882 WhatsApp: +86 13392835756

Email: clayson.uk@gmail.com

奇點品牌策劃 +86 152 1755 8369

產品宣傳畫冊 / 品牌 VIS 策劃 / 展廳視覺設計